



# PRO RUNNER X

Owner's Manual





## IMPORTANT! PLEASE READ:

**If you purchased your 3G Cardio product from an online retailer** (3GCardio.com, Amazon, etc..) and need help or have questions, comments or concerns, please call or email us (3G Cardio) directly. We are not operators, we are experienced fitness professionals and can help you with anything and everything!

**If you purchased your 3G Cardio product from a “brick and mortar” retail store**, feel free to contact the store directly with any questions or concerns. You are still more than welcome to contact us too!

### **Things to know about your new 3G Cardio Treadmill:**

- 1) Your new 3G Cardio treadmill will take about 50 – 70 miles to break in. During this time the treadmill will quiet down, and the suspension will soften.
- 2) You may hear a “tha-thump” sound as the seam of the walking belt travels over the front and rear rollers. This is normal and will fade with time.
- 3) The walking belt itself may sound noisy as you walk, and it may feel “grabby” under your feet. This is normal and will quiet with time.
- 4) The suspension will soften during this time. You may hear “creaking” or an occasional “popping” sound as the treadmill frame settles, also normal.
- 5) If your walking belt feels like it is “slipping,” “pausing” or “stopping” when you walk, there is nothing wrong with the treadmill. The walking belt simply needs to be adjusted. Instructions on how to adjust the belt are in the owner’s manual, or you can call us at 888-888-7985 (Ext 2) and we will walk you through the process.

Thank you and we appreciate your business!

**1-888-888-7985**  
**www.3GCardio.com**  
**support@3gcardio.com**

3G Cardio Fitness Equipment  
14647 So. 50th Street Suite 110  
Phoenix, AZ 85044

© Copyright 3G Cardio LLC  
All Rights Reserved

# TABLE OF CONTENTS

SAFETY	1 - 2
WARM UP & COOL DOWN	3
UNPACKING	4
MOVING THE TREADMILL	5
ASSEMBLY INSTRUCTIONS	5 - 6
COMPUTER OPERATIONS	7 - 14
BLUETOOTH	15
BELT ADJUSTMENT	16 - 17
CARE & MAINTENANCE	18
LUBRICATION MAINTENANCE	19
TROUBLE SHOOTING	20
PARTS LIST	21
PARTS LIST - BOLTS	22
EXPLODED DRAWING	23
WARRANTY	24

## SAFETY

**IMPORTANT: Read all instructions and warnings before using treadmill.**

### IMPORTANT VOLTAGE INFORMATION!

Before plugging the power cord into an electrical outlet, verify that the voltage requirements for your area match the voltage of the treadmill that you have received. The power requirements for this treadmill include a grounded, dedicated circuit, rated for one of the following: 115VAC +- 5%, 60Hz and 20amps; 208/220 VAC, 60Hz, 15amps or 230 VAC +- 5%, 50Hz and 10amps. Use of wrong voltage will damage the treadmill.

### GROUNDING INSTRUCTIONS:

This treadmill must be grounded. If it should malfunction or break down, grounding provides a path of least resistance for electric current to reduce the risk of electric shock. This treadmill has a power cord which has a grounding conductor and grounding plug. The plug must be plugged into an appropriate outlet that is properly installed and grounded in accordance with all local codes and ordinances.

### DANGER!

Improper connection of the equipment-grounding conductor can result in a risk of electric shock. Check with a qualified electrician or service provider if you are in doubt as to whether the treadmill is properly grounded.

### CONSULT A PHYSICIAN IMMEDIATELY!

**Warning:** Before starting any exercise program consult your physician. This is especially important for individuals over the age of 35 or persons with preexisting health problems. Read all instructions before using any fitness equipment. 3G Cardio LLC assumes no responsibility for personal injury or damage sustained by or through the use of this treadmill.

### IMPORTANT SAFETY INSTRUCTIONS:

- Obtain a medical exam before beginning any exercise program.
- Keep children and pets away from the treadmill. Teenagers and disabled persons must be supervised while using the treadmill.
- Stop exercising if you feel faint, dizzy, or experience pain at any time while exercising and consult your physician.
- Clip the SAFETY KEY onto your clothing and carefully test it prior to using the treadmill.
- Disconnect all power before servicing the treadmill.
- Connect the treadmill to a properly grounded outlet only.
- Do not operate treadmill in damp or wet locations.
- Disengage the SAFETY KEY when not in use.
- Inspect the treadmill for worn or loose components before each use.
- Do not operate the treadmill if:
  - 1) The power cord is damaged.
  - 2) The treadmill is not working properly.
  - 3) The treadmill has been dropped or damaged.
- Do not use the treadmill outdoors.
- Read and understand this owner's manual completely before using the treadmill.
- Read and understand all warnings posted on the treadmill and in this owner's manual.
- Do not wear loose or dangling clothing while using the treadmill.
- Always wear proper footwear on or around exercise equipment.
- Set up and operate the treadmill on a solid, level surface.
- Provide the following clearances: 1 foot clearance on right and left side, 5 feet of clearance behind the running belt and enough room for safe access at the front of the treadmill.
- Modifying this treadmill in any way will void all warranties.

# SAFETY

## TARGET HEART RATE ZONE

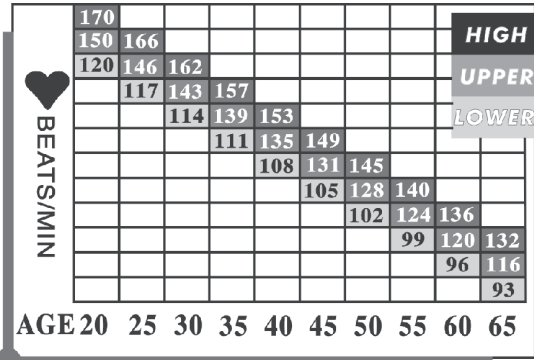

**Target Heart Rate Zone**  
 $220 - \text{Your Age} = \text{Maximum Heart Zone}$

You do not want to workout at your maximum heart rate. The recommended Heart Rate Zone is a percentage of your maximum heart rate. Between 60% and 75% of your maximum heart rate.

Lower limit of Target Heart Rate Zone = Maximum heart rate X 0.6  
 Upper limit of Target Heart Rate Zone = Maximum heart rate X 0.75

### HOW OFTEN SHOULD YOU EXERCISE?

You should exercise three to four times a week, 30 minutes per workout, or as instructed by your doctor.

### HOW HARD SHOULD YOU EXERCISE?

Intensity of exercise is reflected in your heart rate. Exercise must be sufficiently rigorous to strengthen your heart muscle and condition your cardiovascular system. Before starting any exercise program consult your physician.

### HOW LONG SHOULD YOU EXERCISE?

Sustained exercise conditions your heart, lungs and muscles. The longer you are able to sustain exercise within your target heart range, the greater the aerobic benefits. You should always begin a workout with at least a 5 minute warm up at low intensity.

## BEGINNER TREADMILL PROGRAM

	EXERTION LEVEL	DURATION
WEEK 1	Easy	6 – 12 Minutes
WEEK 2	Easy	10 – 16 Minutes
WEEK 3	Moderate	14 – 20 Minutes
WEEK 4	Moderate	18 – 24 Minutes
WEEK 5	Moderate	22 – 28 Minutes
WEEK 6	Slightly higher or slightly lower	20 Minutes
WEEK 7	Add interval training	3 minutes at moderate, then 3 minutes at higher exertion, then 3 minutes at easy. Continue this pattern for 24 minutes.

## WARM UP & COOL DOWN

### WARM UP & COOL DOWN

A successful exercise program consists of a warm up, aerobic exercise, and a cool down. Warming up is an important part of your workout, and should begin every session. It prepares your body for more strenuous exercise by heating up and stretching out your muscles. At the end of your workout, repeat these exercises to properly cool down. We suggest the following warm up and cool down exercises:

1

#### Head Rolls

Rotate your head to the right for one count, feeling the stretch up the left side of your neck. Next rotate your head back for one count, stretching your chin to the ceiling and letting your mouth open. Rotate your head to the left for one count, and finally, drop your head to your chest for one count.



5

#### Toe Touches

Slowly bend forward from your waist, letting your back and shoulder relax as you stretch toward your toes. Reach down as far as you can and hold for 15 seconds.



2

#### Shoulder Lifts

Lift your right shoulder up toward your ear for one count. Then lift your left shoulder up for one count as you lower your right shoulder.



6

#### Quadriceps Stretch

With one hand against a wall for balance, reach behind you and pull your right foot up. Bring your heel as close to your buttocks as possible. Hold for 15 counts and repeat with left foot up.



3

#### Side Stretches

Open your arms to the side and continue lifting them until they are over your head. Reach your right arm as far upward toward the ceiling as you can for one count. Feel the stretch up your right side. Repeat this action with your left arm.



7

#### Hamstring Stretches

Sit with your right leg straight in front of you. Straighten your leg out while trying to hold on to your outstretched leg with your hand. Starting up with your back straight. Slowly exhale and try to bring your chest to the knee of your outstretched leg. Hold, then repeat on the other side for 15 seconds.



4

#### Inner Thigh Stretch

Sit with the soles of your feet together with your knees pointing outward. Pull your feet as close into your groin as possible. Gently push your knees toward the floor. Hold for 15 counts.



8

#### Calf / Achilles Stretch

Lean against a wall with your left leg in front of the right and your arms forward. Keep your right leg straight and the left foot on the floor; then bend the left leg and lean forward by moving your hips toward the wall. Hold, then repeat on the other side for 15 seconds.



# UNPACKING INSTRUCTIONS

## Warning!



Use extreme caution when assembling or moving this treadmill. Failure to do so could result in injury.

**NOTE:** Each step number in the assembly instructions will tell you how to properly complete the installation process. Read and understand all instructions thoroughly before attempting to assemble or move this treadmill.

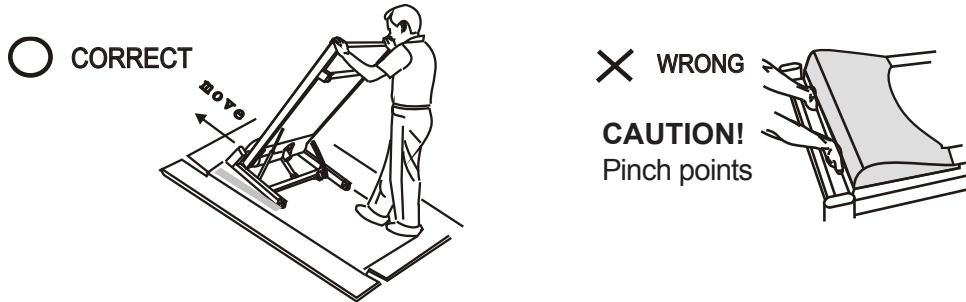

Failure to follow this procedure may result in serious injury due to pinch point area on the front frame near the motor cover.

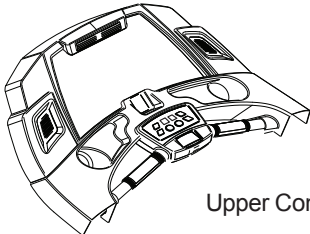
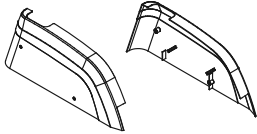
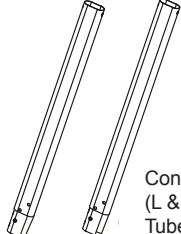
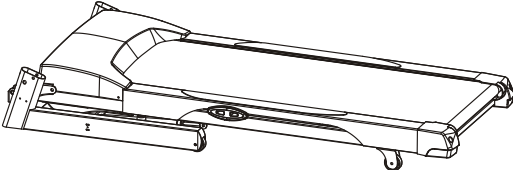
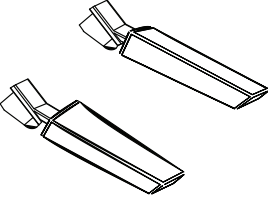

If any of the below parts are missing, contact your local 3G Cardio Retailer.

 <p>Upper Console</p>	 <p>Side Cover (left &amp; right)</p>	 <p>Console Mast (L &amp; R Upright Tubes)</p>
 <p>Main Body - Base Frame</p>	 <p>Handlebars</p>	 <p>Hardware Kit</p>

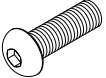
## HARDWARE KIT

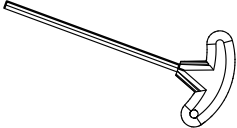
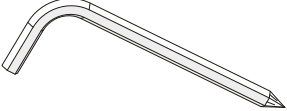
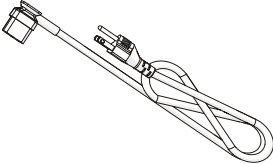
 <p>Self tapping screw Ø4X10mm 4pcs</p>	 <p>M8X40mm hex socket head bolt 4pcs (Handlebar and Console)</p>	 <p>M8X15mm hex socket head bolt 14pcs (base frame and console)</p>	 <p>Lubricant for running deck</p>
 <p>M5 wrench</p>	 <p>M5 Allen wrench</p>	 <p>Power cord</p>	

# ASSEMBLY INSTRUCTIONS

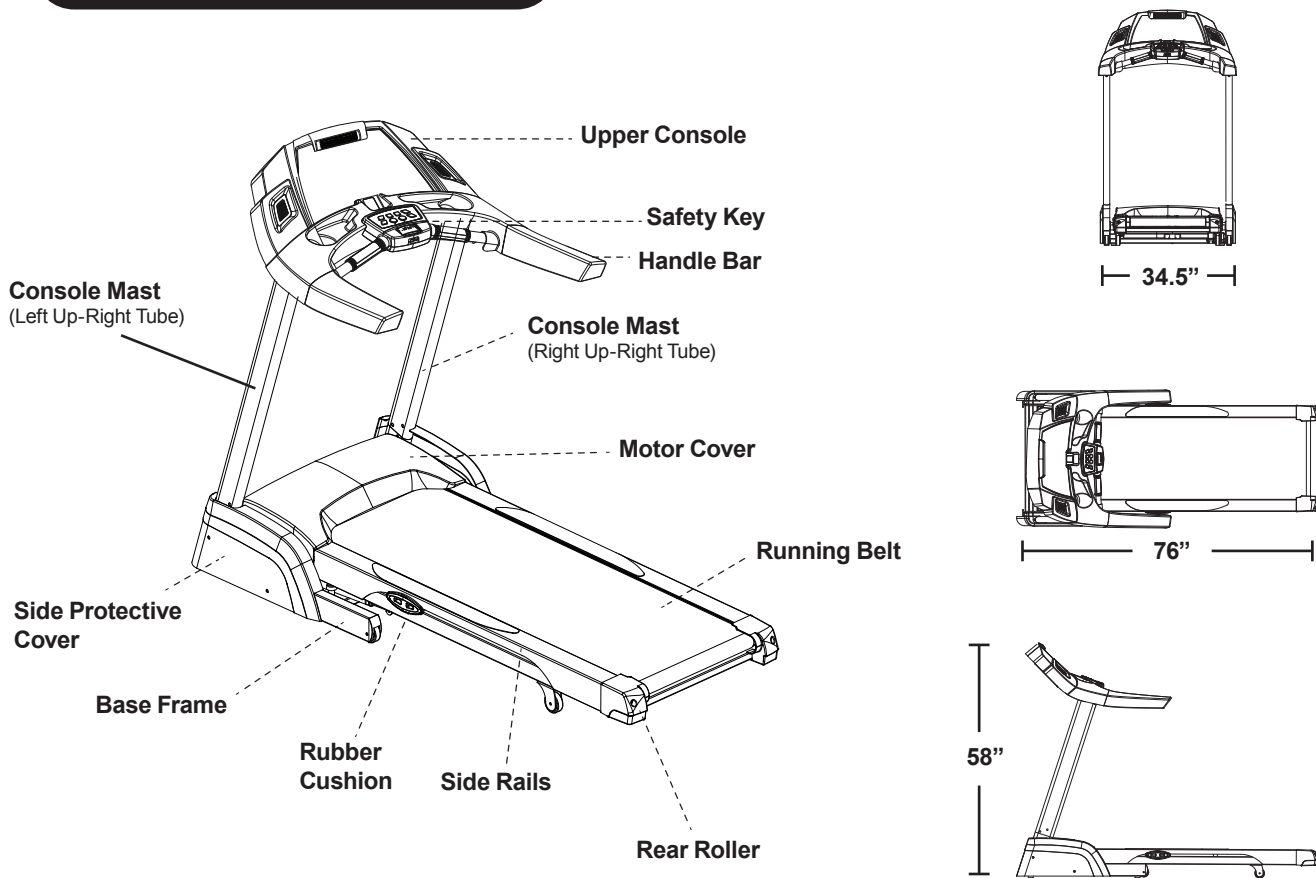

## Instructions for moving Treadmill:

This treadmill is designed with wheels for easier movement.

1. Make sure the treadmill elevation is at the lowest level of 0%
2. Turn off treadmill, unplug the power cord from the wall and from the base of the treadmill. Failure to do so will result in damage to the power cord and power inlet.
3. Fold up treadmill and make sure the treadmill deck LOCKS into position. Once the treadmill is locked into a folded "up" position, facing the treadmill, hold onto the handlebars to move the treadmill forward or backwards. Be careful not to "drag" the treadmill as it may damage your flooring. If your treadmill is not easily rolling, inspect underneath the treadmill frame to determine if the rubber floor levelers are touching the floor. If the floor levelers are touching the floor, you may need to adjust them up higher to allow the treadmill to move easier.
4. Once the treadmill is moved into the desired position, unfold the treadmill by releasing the lock (as shown in the illustration) and allow the treadmill deck to lower to the ground. Once unfolded, plug in the treadmill, turn on the power toggle switch and you are ready to go. **IMPORTANT:** make sure that the treadmill is in a safe, secure and level position.

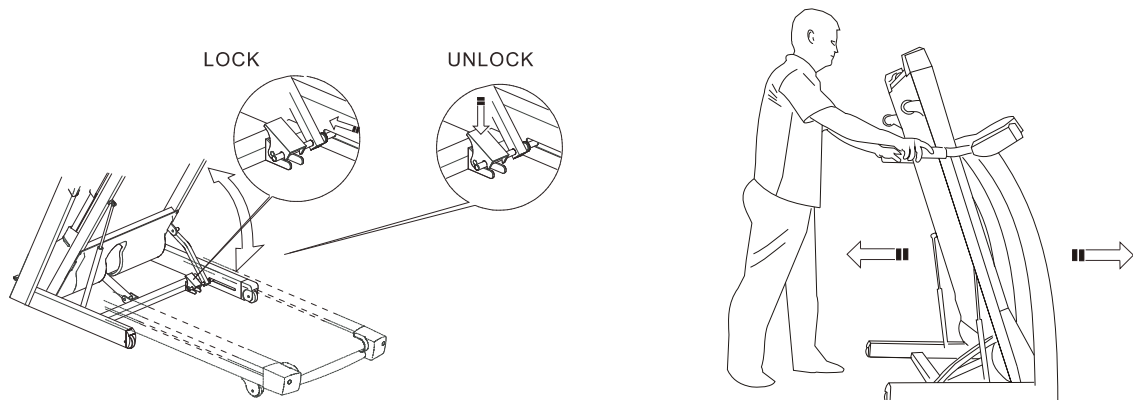



## ASSEMBLY INSTRUCTIONS

### STEP 1 Assemble the Up-Right tubes onto Base Frame.

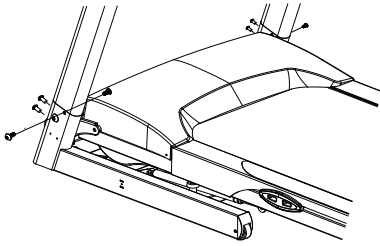

(A) Assemble the left Up-Right tube onto the left side of the Base Frame, use four M8X15mm bolts and the Allen wrench, but do not tighten yet.

(B) There is a preinstalled guide cable inside the right side Up-Right tube. Attach the lower Console Data Cable & Ground Cable from the motor cavity area to the guide cable. Once attached, find the top portion of the guide cable at the top of the Up-Right tube and pull the guide cable up through the tube until the attached Console Data Cable & Ground Cable are exposed. At this point, secure the cable for later use. Note: make sure that you do not allow the cable set to slip back down the Up-Right tube. Assemble the right Up-Right tube onto the right side of the Base Frame. Use four M8X15mm bolts and the Allen wrench, but do not tighten yet.

### STEP 4 Assemble the Upper Console onto the Up-Right tubes.

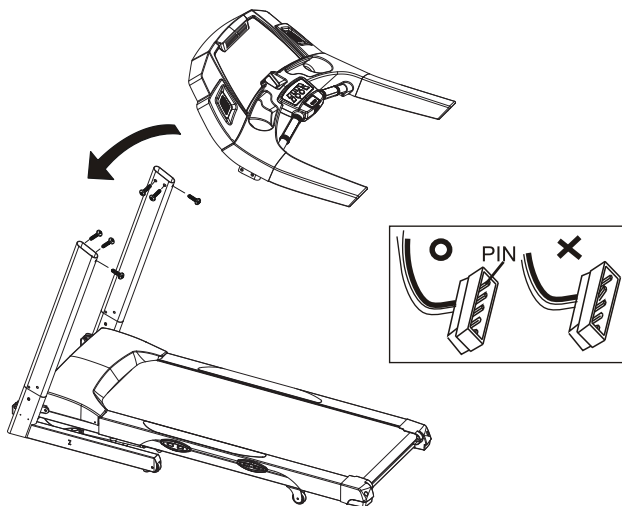

(A) Plug and connect the Console Cable and Ground Cable from the right Up-Right tube to the cables from the Upper Console: Do not “force” connection, make sure the pins line up evenly. Failure to do so may cause the pins to bend which will prevent the treadmill from working properly. Refer to attached drawing. Once the cables are attached to each other, place the entire Upper Console onto the Up-Right tubes. (Make sure not to pinch Data Cables between Upper Console and Up-Right tubes). Align the bolt holes from both Up-Right tubes with the bolt holes from the Upper Console and insert and tighten 6 pieces of M8X15mm bolt as shown. Again, make sure that cables are not pinched between any parts of the treadmill.

### STEP 2 Assemble the handle bars into the console.

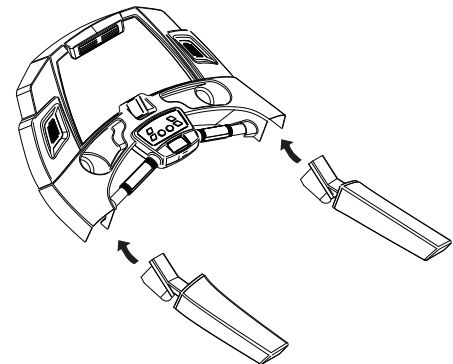

### STEP 3 Screw the M8x40mm bolts onto the handle bars and tighten.

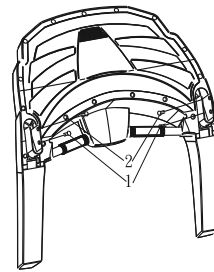

(A) Secure the handle bars onto the upper console. Insert and tighten bolts as shown in diagram #1 and #2.

### STEP 5 Assemble the side covers to the main body.

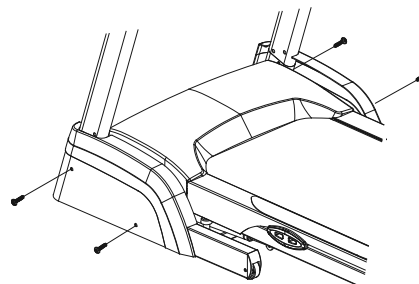

(A) Assemble the side covers to base frame using screw 4X10mm and the Allen wrench.

# COMPUTER OPERATIONS

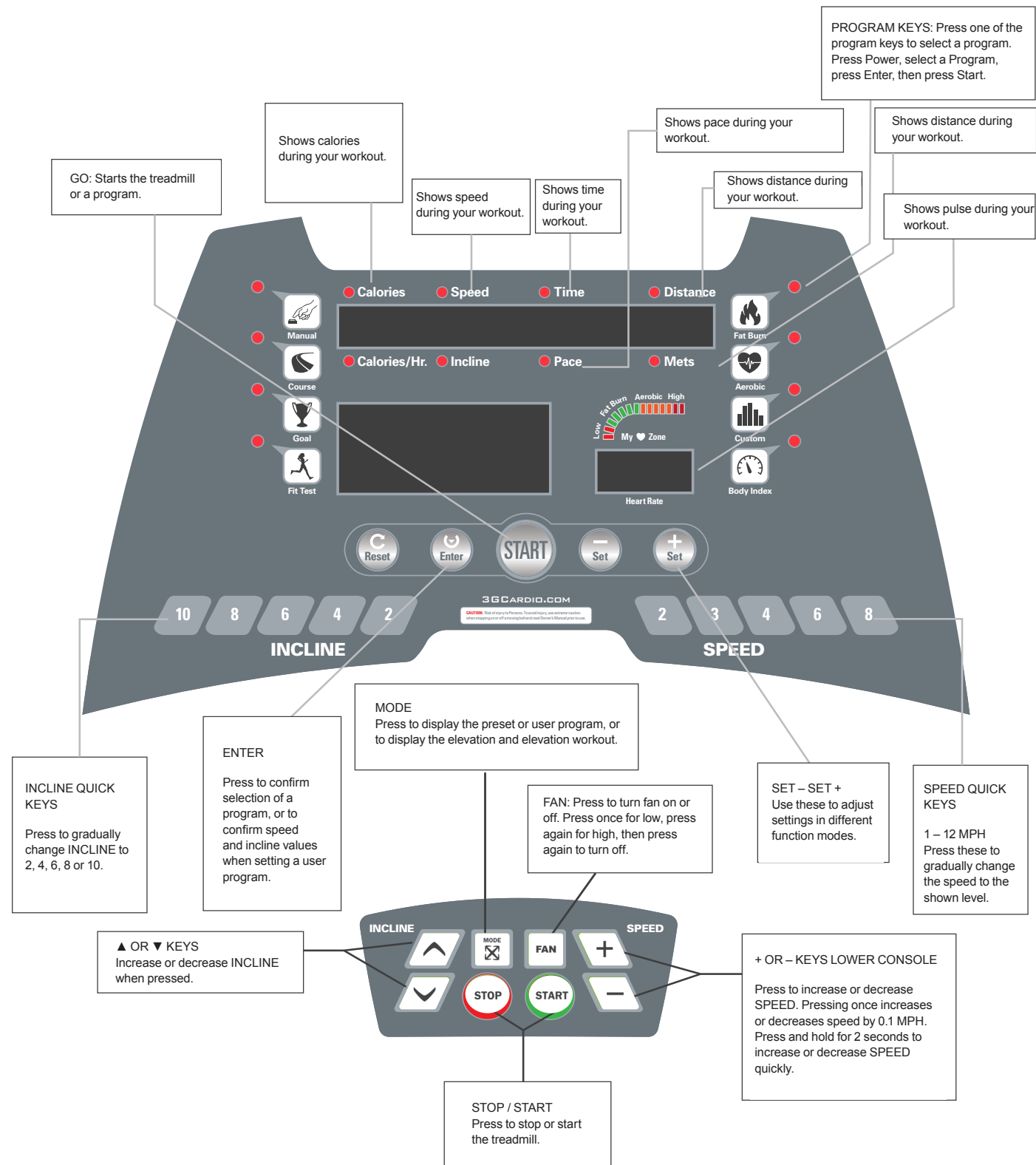

## COMPUTER OPERATIONS

### Control Panel Function

<b>Speed</b>	Indicates the current speed of the walking belt in MPH.
<b>Time</b>	Indicates remaining or elapsed time of the current program.
<b>Calories</b>	Indicates total accumulated calories burned.
<b>Incline</b>	Indicates current level of incline or elevation in 1% increments with a max of 15%.
<b>Distance</b>	Indicates the total distance of your workout.
<b>Pace</b>	Indicates how long it will take to reach 1 mile.
<b>Calories / h</b>	Indicates the current amount of calories burned.
<b>Mets</b>	METS represent how much harder your body is working than if it were at rest.

### Console Key Functions

<b>Speed – / +</b>	Adjust the speed (MPH) of the treadmill belt.
<b>Incline ^ / v</b>	Adjust the elevation up or down.
<b>Fan</b>	Adjust the speed of the fan: High - Low - Off.
<b>Mode</b>	Toggle the available information displayed in the workout windows.
<b>Stop</b>	1. Pause the treadmill belt 2. End the workout 3. Reset.
<b>Start</b>	Pressing the START button will cause the treadmill belt to start.
<b>Manual</b>	In this mode, USER predetermines TIME, SPEED, LEVEL and ELEVATION.
<b>Course</b>	Select this mode to choose built in preprogrammed workouts.
<b>Goal</b>	Select this mode to predetermine your desired TIME, DISTANCE and CALORIES.
<b>Fit Test</b>	Select this mode to choose between the GERKIN or COOPER fitness test.
<b>Fat Burn</b>	Select this mode to choose the FAT BURN program.
<b>Aerobic</b>	Select this mode to choose the AEROBIC program.
<b>Custom</b>	Select this mode to customize your own workout.
<b>Body Index</b>	Select this mode to estimate your BMI, BMR or BFR (See page 12 for more information)
<b>Start</b>	Press this button on the lower console to start the treadmill or resume from "PAUSE" mode.
<b>Enter</b>	Press the ENTER button to confirm the function or information you set.
<b>Reset</b>	Press the RESET button to delete all current settings and return to the start up screen.
<b>Set – +</b>	Press the SET button to select the desired program or enter program details.
<b>Speed (One Touch)</b>	Press desired speed button to select specific MPH.
<b>Incline (One Touch)</b>	Press desired incline button to select specific elevation.

## COMPUTER OPERATIONS

### Quick Start

Press START to start the treadmill. The display will count down 3-2-1 then the belt will start moving at the slowest speed. Use SPEED +/- and INCLINE +/- to adjust the treadmill.

### Cool Down:

Cool down is designed to gradually slow down the speed of the treadmill and safely bring you out of your heart rate zone. The COOL DOWN program will start automatically 4 minutes prior to the end of the workout. In a COOL DOWN program, the incline will automatically be set at 0% and the speed will be reduced by 50% every 60 seconds until the end of the program or until the treadmill reaches its minimum speed.

### Manual:

Manual mode, you are in control of the speed and incline during the workout.

To Use: Press MANUAL button, use SET - + to adjust the workout time, press ENTER. Use SET - + to adjust age, press ENTER. Use SET - + to adjust weight, press ENTER. Use SET - + to adjust starting speed, press ENTER. Use SET - + to adjust starting incline, press ENTER. Press START to start workout.

### Course:

Choose from 8 different courses, the treadmill will control the speed and incline during the program.

To Use: Press COURSE button, use SET - + to select a course program. Choose from: Ramp-Speed, Ramp-Incline, Interval-Speed, Interval-Incline, Hill-Speed, Hill-Incline, Peak-Incline, And Peak-Speed. When the program you want displays press ENTER. Use SET - + and enter to adjust starting level, weight, and age. Press START to begin workout.

### Goal

Goal based programs allow you to reach a distance, calorie, or time goal for your workout.

To Use: Press GOAL button. Use SET - + and ENTER to adjust your workout goal of; time, target distance, or target calories (you may choose multiple goals or set just one like "target calories"). Use SET - + and ENTER to adjust age, weight, starting speed, and starting incline. Press START to begin workout.

## COMPUTER OPERATIONS

**NOTE:** A “Wireless Heart Rate Strap” is needed for certain programs but is not included with this treadmill. You can purchase a universal wireless heart rate strap from your local fitness retailer.

### Fit Test:

**Heart rate and distance based fitness tests. Select either the Cooper Test or the Gerkin Protocol.**

**Always consult with your doctor to confirm you are healthy enough for exercising on a treadmill.** The Cooper Test and the Gerkin Protocol are designed to take you to a high level heart rate zone. If at any point you feel faint or dizzy immediately drop your speed and incline to a more comfortable intensity or stop exercising. The Cooper Test determines how far a person can walk during a 12 minute workout. The Gerkin Protocol estimates your cardiovascular endurance by incrementally making the treadmill speed and incline more difficult until your target heart rate is reached. How long it takes to reach your target heart rate zone will determine your fitness level. This reading is only an estimate.

**Cooper Test:** Press FIT TEST button. Use SET - + to select COOPER TEST. Use SET - + and ENTER to adjust male/female, age, and weight. The goal is to reach your maximum distance in 12 minutes. Set the speed and incline to a comfortable level.

AGE	GENDER	VERY GOOD	GOOD	AVERAGE	BAD	VERY BAD
13-14	Male	>1.67Mi	1.49-1.67 Mi	1.36~1.48 Mi	1.3~1.36 Mi	<1.3 Mi
	Female	>1.24Mi	1.18~1.24Mi	0.99~1.17 Mi	0.93~0.99 Mi	<0.93 Mi
16-17	Male	>1.74Mi	1.55~1.74Mi	1.43~1.54 Mi	1.36~1.42 Mi	<1.36 Mi
	Female	>1.30Mi	1.24~1.30Mi	1.18~1.23 Mi	0.99~1.17 Mi	<0.99 Mi
17-20	Male	>1.86Mi	1.67~1.86Mi	1.55~1.67 Mi	1.43~1.54 Mi	<1.43 Mi
	Female	>1.43Mi	1.3~1.43 Mi	1.12~1.3 Mi	1.05~1.11 Mi	<1.05 Mi
21-29	Male	>1.74Mi	1.49~1.74Mi	1.36~1.48 Mi	0.99~1.36 Mi	<0.99 Mi
	Female	>1.67Mi	1.36~1.67Mi	1.19~1.36 Mi	0.93~1.11 Mi	<0.93 Mi
30-39	Male	>1.67Mi	1.43~1.67Mi	1.18~1.42 Mi	0.93~1.17 Mi	<0.93 Mi
	Female	>1.55Mi	1.24~1.55Mi	1.05~1.23 Mi	0.87~1.05 Mi	<0.87 Mi
40-49	Male	>1.55Mi	1.3~1.55 Mi	1.05~1.3 Mi	0.87~1.05 Mi	<0.87 Mi
	Female	>1.43Mi	1.18~1.43Mi	0.93~1.17 Mi	0.74~0.92 Mi	<0.74 Mi
Over 50	Male	>1.49Mi	1.24~1.49Mi	0.99~1.23 Mi	0.80~0.99 Mi	<0.80 Mi
	Female	>1.36Mi	1.05~1.36Mi	0.87~1.05 Mi	0.68~0.86 Mi	<0.68 Mi

**Gerkin:** Press FIT TEST button. Use SET - + to select Gerkin Protocol. Use SET - + and ENTER to adjust male/female, age, and weight. When the display reads “take pulse” put on a wireless heart rate strap (you must wear a hear rate strap for the Gerkin Protocol), once a number displays in the HR window. Press START to begin workout.

SEG	Total Time	Speed(MPH)	Incline	VO2 Max.	SEG	Total Time	Speed(MPH)	Incline	VO2 Max.
1	1:00	4.5	0	31.15	7	7:00	6.0	6	57.7
2	2:00	4.5	2	32.55		7:15	6.0	6	58.8
	2:15	4.5	2	33.6		7:30	6.0	6	60.2
	2:30	4.5	2	34.65		7:45	6.0	6	61.2
	2:45	4.5	2	35.35	8:00	6.0	8	62.3	
3	3:00	5.0	2	37.45	8	8:15	6.0	8	63.3
	3:15	5.0	2	39.55		8:30	6.0	8	64
	3:30	5.0	2	41.3		8:45	6.0	8	65
	3:45	5.0	2	43.4		9:00	6.5	8	66.5
4	4:00	5.0	4	44.1	9	9:15	6.5	8	68.2
	4:15	5.0	4	45.15		9:30	6.5	8	69
	4:30	5.0	4	46.2		9:45	6.5	8	70.7
	4:45	5.0	4	46.5		10:00	6.5	10	72.1
5	5:00	5.5	4	48.6	10	10:15	6.5	10	73.1
	5:15	5.5	4	50		10:30	6.5	10	73.8
	5:30	5.5	4	51.4		10:45	6.5	10	74.9
	5:45	5.5	4	52.8		11:00	7.0	10	76.3
6	6:00	5.5	6	53.9	12	Cool Down / SEG 16~24 unavailable.			
	6:15	5.5	6	54.9	13				
	6:30	5.5	6	56	14				
	6:45	5.5	6	54	15				

## GERKIN PROTOCOL RESULTS

MALE

AGE	EXCELLENT	GOOD	ABOVE AVERAGE	AVERAGE	BELOW AVERAGE	POOR	VERY POOR
18~25	>60	52~60	47~51	42~46	37~41	30~36	<30
26~35	>56	49~56	43~48	40~42	35~39	30~34	<30
36~45	>51	43~51	39~42	35~38	31~34	26~30	<26
46~55	>46	39~45	35~38	32~34	29~31	25~28	<25
56~65	>41	36~41	32~35	30~31	26~28	22~25	<22
66+	>37	33~37	29~32	26~28	22~25	20~21	<20

FEMALE

AGE	EXCELLENT	GOOD	ABOVE AVERAGE	AVERAGE	BELOW AVERAGE	POOR	VERY POOR
18~25	>56	47~56	42~46	38~41	33~37	28~32	<28
26~35	>52	45~52	39~44	35~38	31~34	26~30	<26
36~45	>45	38~45	34~37	31~33	27~30	22~26	<22
46~55	>40	34~40	31~33	28~30	25~27	20~24	<20
56~65	>37	32~37	28~31	25~27	22~24	18~21	<18
66+	>32	28~32	25~27	22~24	19~21	17~18	<17

### Fat Burn

#### Heart Rate based training to help maximize weight loss.

To Use: Press FAT BURN button. Use SET - + and ENTER to adjust workout time and age. The treadmill will automatically display your recommended Target Heart Rate Zone. Use SET - + to set your desired Target Heart Rate (see "Target Heart Rate Zone" for more information on page 2). In the FAT BURN program, the treadmill will automatically adjust the speed and incline to keep you at your desired target heart rate to help maximize weight loss.

Next, set your weight, starting speed, and starting incline. When the display reads; "take pulse," you will need to either use a wireless heart rate strap (not included) or hold onto the contact heart rate grips. Press START to begin workout. Please be aware that in the FAT BURN program, a constant heart rate signal will be needed in order use this program.

### AEROBIC

#### Heart Rate based training to help maximize aerobic benefit.

To Use: Press AEROBIC button. Use SET - + and ENTER to adjust workout time and age. The treadmill will automatically display your recommended Target Heart Rate Zone. Use SET - + to set your desired Target Heart Rate (see "Target Heart Rate Zone" for more information on page 2). In the AEROBIC program, the treadmill will automatically adjust the speed and incline to keep you at your desired target heart rate.

Next, set your weight, starting speed, and starting incline. When the display reads; "take pulse," you will need to either use a wireless heart rate strap (not included) or hold onto the contact heart rate grips. Press START to begin workout. Please be aware that in the AEROBIC program, a constant heart rate signal will be needed in order use this program.

## COMPUTER OPERATIONS

### CHEST STRAP TRANSMITTER (Not Included)

To operate HRC (Heart Rate Control), the user needs to either wear an optional wireless chest strap transmitter or hold onto the built-in heart rate grips.

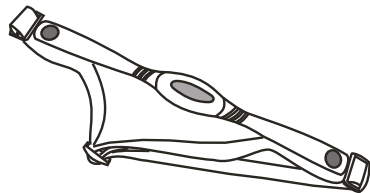

CHEST STRAP (TRANSMITTER)

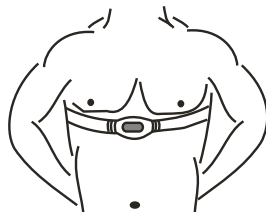

### RECEIVING AREA

Your 3G Cardio Pro Runner Treadmill has a built in Heart Rate Receiver Chip which can receive a signal from a universal wireless heart rate strap.

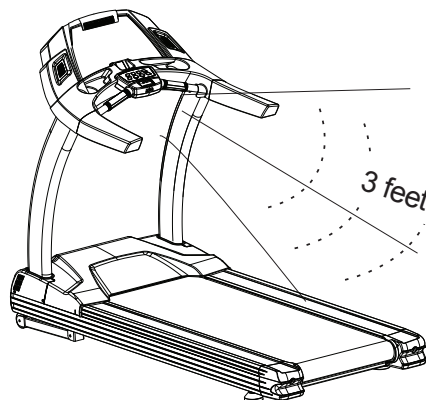

### Custom designing your own personal workout:

Two custom programs are available for you to design, save and reuse. Choose the settings for speed, incline, and time of each segment and the duration of the overall workout.

To Use: Press CUSTOM button. Use SET - + to select Custom 1 or Custom 2. Select age and weight. When "b-01" or segment 1 of the workout displays use incline +/- to change incline, speed +/- to change speed, and SET - + to adjust the time for that segment of the workout. Press ENTER. Repeat with "b-02" or segment 2. There are 24 segments in the custom program. This program will be saved, simply choose custom 1 or 2 to access your saved workout and press START.

### Body Index

Uses information to provide your BMI (Body Mass Index), BMR (Basal Metabolic Rate), and BFR (Body fat ratio).

To Use: SET - + to select male or female, press ENTER. Select age, weight, and height. Press START. The display will alternate between BMI, BMR, and BFR numbers.

BMI (Body Mass Index)	Result
< 18	Underweight
18 - 25	Normal Range
26 - 30	Overweight
> 30	Obese

**BMR (Basal Metabolic Rate)** Calories burned per day under non-exercise conditions

**BFR (Body fat ratio)** Normal Range: Males 15-25%, Females 20-30%





# COMPUTER OPERATIONS

## Course

SEG = Segment  
SPD = Speed  
INC = Incline

# PEAK MODE

PEAK-SPEED-LEVEL 1



SEG	1	2	3	4	5	6	7	8	9	10	11	12	13	14	15	16	17	18	19	20	21-24
SPD	1	2	3	6	3	1	2	5	6	3	2	1	3	6	8	9	6	4	3	1	Cool Down

PEAK-SPEED-LEVEL 2



SEG	1	2	3	4	5	6	7	8	9	10	11	12	13	14	15	16	17	18	19	20	21-24
SPD	1	2	3	6	3	1	2	5	6	3	2	1	3	6	8	9	6	4	3	1	Cool Down

PEAK-SPEED-LEVEL 3



SEG	1	2	3	4	5	6	7	8	9	10	11	12	13	14	15	16	17	18	19	20	21-24
SPD	3	3	4	4	4	5	5	7	7	8	12	9	7	6	5	4	3	2	2		Cool Down

PEAK-SPEED-LEVEL 4



SEG	1	2	3	4	5	6	7	8	9	10	11	12	13	14	15	16	17	18	19	20	21-24	
SPD	3	3	4	4	5	5	6	7	8	8	9	14	10	8	6	6	5	4	3	3		Cool Down

PEAK-SPEED-LEVEL 5

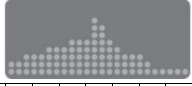

SEG	1	2	3	4	5	6	7	8	9	10	11	12	13	14	15	16	17	18	19	20	21-24	
SPD	4	4	5	6	6	6	7	8	9	9	9	15	14	10	8	6	6	5	4	2		Cool Down

PEAK-INCLINE-LEVEL 1



SEG	1	2	3	4	5	6	7	8	9	10	11	12	13	14	15	16	17	18	19	20	21-24	
INC	1	1	1	1	2	2	2	2	3	4	7	5	4	3	3	2	2	1	1	1		Cool Down

PEAK-INCLINE-LEVEL 2



SEG	1	2	3	4	5	6	7	8	9	10	11	12	13	14	15	16	17	18	19	20	21-24	
INC	1	1	2	2	2	3	3	3	4	5	8	6	5	4	4	3	3	3	2	1		Cool Down

PEAK-INCLINE-LEVEL 3



SEG	1	2	3	4	5	6	7	8	9	10	11	12	13	14	15	16	17	18	19	20	21-24	
INC	1	2	3	3	4	4	5	5	5	6	10	7	6	6	5	5	4	3	2	1		Cool Down

PEAK-INCLINE-LEVEL 4



SEG	1	2	3	4	5	6	7	8	9	10	11	12	13	14	15	16	17	18	19	20	21-24	
INC	1	1	1	1	2	2	2	2	3	4	7	5	4	3	3	2	2	1	1	1		Cool Down

PEAK-INCLINE-LEVEL 5

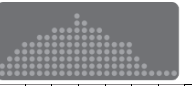

SEG	1	2	3	4	5	6	7	8	9	10	11	12	13	14	15	16	17	18	19	20	21-24	
INC	1	2	3	4	5	6	7	8	8	9	12	10	9	8	6	5	5	4	2	1		Cool Down

SEG = Segment  
SPD = Speed  
INC = Incline

# HILL MODE

HILL-SPEED-LEVEL 1



SEG	1	2	3	4	5	6	7	8	9	10	11	12	13	14	15	16	17	18	19	20	21-24	
SPD	1	1	1	2	2	2	3	3	3	4	4	4	4	4	3	3	2	2	1	1		Cool Down

HILL-SPEED-LEVEL 2



SEG	1	2	3	4	5	6	7	8	9	10	11	12	13	14	15	16	17	18	19	20	21-24	
SPD	3	3	3	4	4	4	5	5	5	6	6	6	6	6	5	5	4	3	2	1		Cool Down

HILL-SPEED-LEVEL 3

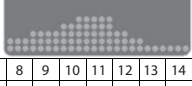

SEG	1	2	3	4	5	6	7	8	9	10	11	12	13	14	15	16	17	18	19	20	21-24	
SPD	3	3	4	5	6	6	6	7	8	9	9	9	9	9	6	5	4	3	2	1		Cool Down

HILL-SPEED-LEVEL 4

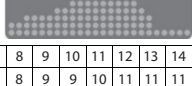

SEG	1	2	3	4	5	6	7	8	9	10	11	12	13	14	15	16	17	18	19	20	21-24	
SPD	3	4	5	6	6	6	7	8	9	9	10	11	11	11	11	11	9	7	5	2		Cool Down

HILL-SPEED-LEVEL 5

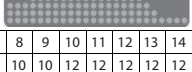

SEG	1	2	3	4	5	6	7	8	9	10	11	12	13	14	15	16	17	18	19	20	21-24	
SPD	5	5	5	7	7	8	8	10	10	12	12	12	12	12	12	12	10	8	6	3		Cool Down

HILL-INCLINE-LEVEL 1



SEG	1	2	3	4	5	6	7	8	9	10	11	12	13	14	15	16	17	18	19	20	21-24	
INC	1	1	2	2	2	3	3	3	5	5	5	5	5	4	4	4	3	2	1	1		Cool Down

HILL-INCLINE-LEVEL 2

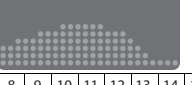

SEG	1	2	3	4	5	6	7	8	9	10	11	12	13	14	15	16	17	18	19	20	21-24	
INC	2	2	3	3	3	4	4	4	7	7	7	7	7	6	5	4	4	3	2	1		Cool Down

HILL-INCLINE-LEVEL 3

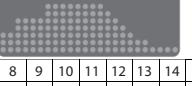

SEG	1	2	3	4	5	6	7	8	9	10	11	12	13	14	15	16	17	18	19	20	21-24	
INC	2	2	4	4	5	5	8	8	8	8	8	8	8	8	6	5	3	2	1	1		Cool Down

HILL-INCLINE-LEVEL 4

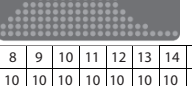

SEG	1	2	3	4	5	6	7	8	9	10	11	12	13	14	15	16	17	18	19	20	21-24	
INC	1	2	3	4	5	6	10	10	10	10	10	10	10	10	8	6	3	2	1	1		Cool Down

HILL-INCLINE-LEVEL 5



SEG	1	2	3	4	5	6	7	8	9	10	11	12	13	14	15	16	17	18	19	20	21-24	
INC	2	3	4	5	6	8	12	12	12	12	12	12	12	12	10	8	5	3	2	1		Cool Down

**IMPORTANT MESSAGE ABOUT Bluetooth® – PLEASE READ!**

**We have created videos to help you get started. You can check these videos out here:**

[www.3gcardio.com/connect](http://www.3gcardio.com/connect)

**What you need to know about Bluetooth®:**

**NOTICE:** This treadmill console is equipped with an FTMS Bluetooth® interface. Please take note that your mobile device or tablet needs to be compatible with the Bluetooth® interface (Bluetooth® 4.0 or above). To use training apps, you will have to activate (turn on) the Bluetooth® function on your mobile device (tablet or smart phone) and start the fitness app.

**IMPORTANT!** Once you turn on the Bluetooth® feature on your device, open the fitness app of your choice and follow the instructions. The app should explain to you the order of events for connecting to the treadmill. Please follow the instructions given in the app.

The specific Bluetooth name of your 3G Cardio treadmill will be “3G CARDIO XXXX” – the X will represent the last 4 digits of your treadmill serial number.

Please note that some fitness apps may have the ability to control the treadmill INCLINE but never SPEED. This is designed for your safety.



Kinomap™ and Zwift™ are examples of some fitness apps you can try out. Please note that these apps are produced by 3rd party designers. 3G Cardio cannot endorse or approve any 3rd party design software or their success, accuracy, privacy or safety. We also do not track changes in 3rd party software so what may work today with our machines may not work tomorrow.

# BELT ADJUSTMENT

## BELT ADJUSTMENT:

**IMPORTANT: DO NOT OVER TIGHTEN THE TREADMILL BELT! THIS WILL VOID YOUR BELT WARRANTY!**

You may need to adjust the running belt during the first few weeks of use. Over time, you will need to adjust it less frequently as the running belt will adjust to your walking or running style. The treadmill belt may stretch or become off-center within the first few weeks or months and this is perfectly normal during the break-in period.

### ADJUSTING THE TREADMILL BELT TENSION:

If the running belt feels as though it is “slipping” or hesitating when you plant your foot during a run, the tension on the treadmill belt may have to be increased. Again, this is normal and easy to rectify.

- Place a hex wrench on the LEFT side tension bolt. Turn the wrench clockwise 1/4 turn to draw the rear roller and increase the belt tension.
- Repeat STEP A on the RIGHT belt tension bolt. You must be sure to turn both bolts the same number of turns, so the rear roller will stay square relative to the frame.
- After completing STEP A and STEP B, walk on the treadmill to determine if the “slip” is gone.
- Repeat STEP A and STEP B until the slipping is eliminated.
- Be careful not to over tighten the treadmill belt as you can create excessive pressure on the front and rear roller bearings and or tear the running belt seam. An excessively tightened running belt will damage the roller bearings and treadmill belt.
- If your belt is no longer “slipping” but off center, STOP and read below for how to center the treadmill belt.

**TO DECREASE THE TENSION ON THE TREADMILL BELT, TURN BOTH BOLTS COUNTER- CLOCKWISE THE SAME NUMBER OF TURNS.**

**IMPORTANT:** If your treadmill belt is rubbing on the side frame or is very close to touching the side frame you will need to center the treadmill belt with the treadmill off. Once you adjust the rear tension bolts properly, then turn the treadmill on to 2.0mph (no faster) and with your foot, manually “push” the treadmill belt away from the side rail. This will safely remove the belt from the side rail and speed up the “centering” process.

### CENTERING THE TREADMILL BELT

When you walk or run, you may push off harder with one foot than the other. The severity of the deflection depends on the amount of force that one foot exerts in the relation to the other. This deflection can cause the treadmill belt to move off center. This deflection is normal and the treadmill belt should center on its own when the treadmill is unoccupied. If the treadmill belt remains consistently off-center, you will need to center the treadmill belt manually (see below).

- Observe the treadmill belt and see if it is touching either the right or left side of the frame. If it is, read the IMPORTANT instructions above!
- Start the treadmill without anyone on the treadmill belt, press (SPEED UP) button until speed reached 3 mph.
- Observe whether the treadmill belt is closer to the right or left side of the deck.

If you need to align the treadmill belt from the left side to right side, always adjust the left side bolt only. The simple rule of thumb for aligning the belt is this: working from the (user) left side bolt, if you need to move the belt to the right, “tighten” the left side bolt (turn clockwise in 1/4 turns only). This will move the belt slightly to the right.

If you need to align the belt to the left, “loosen” the left side bolt (turn the bolt counter clockwise in 1/4 turns only). This will move the treadmill belt to the left. Anytime you need to either tighten the belt or align the belt, you should have the treadmill running at around 3.0 mph. Also, these adjustments can take up to 30 seconds to alter the position of the belt so be patient.

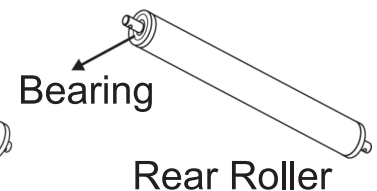
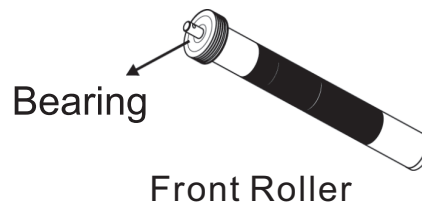
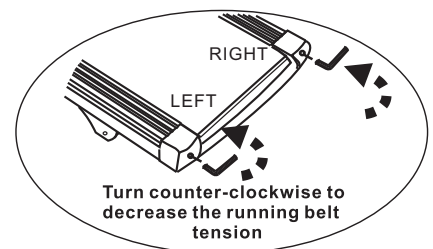
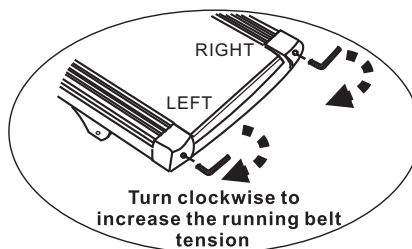

**NEVER OVER TIGHTEN THE TREADMILL BELT AS IT WILL RUIN YOUR TREADMILL!**

## ONE TIME BELT ADJUSTMENT

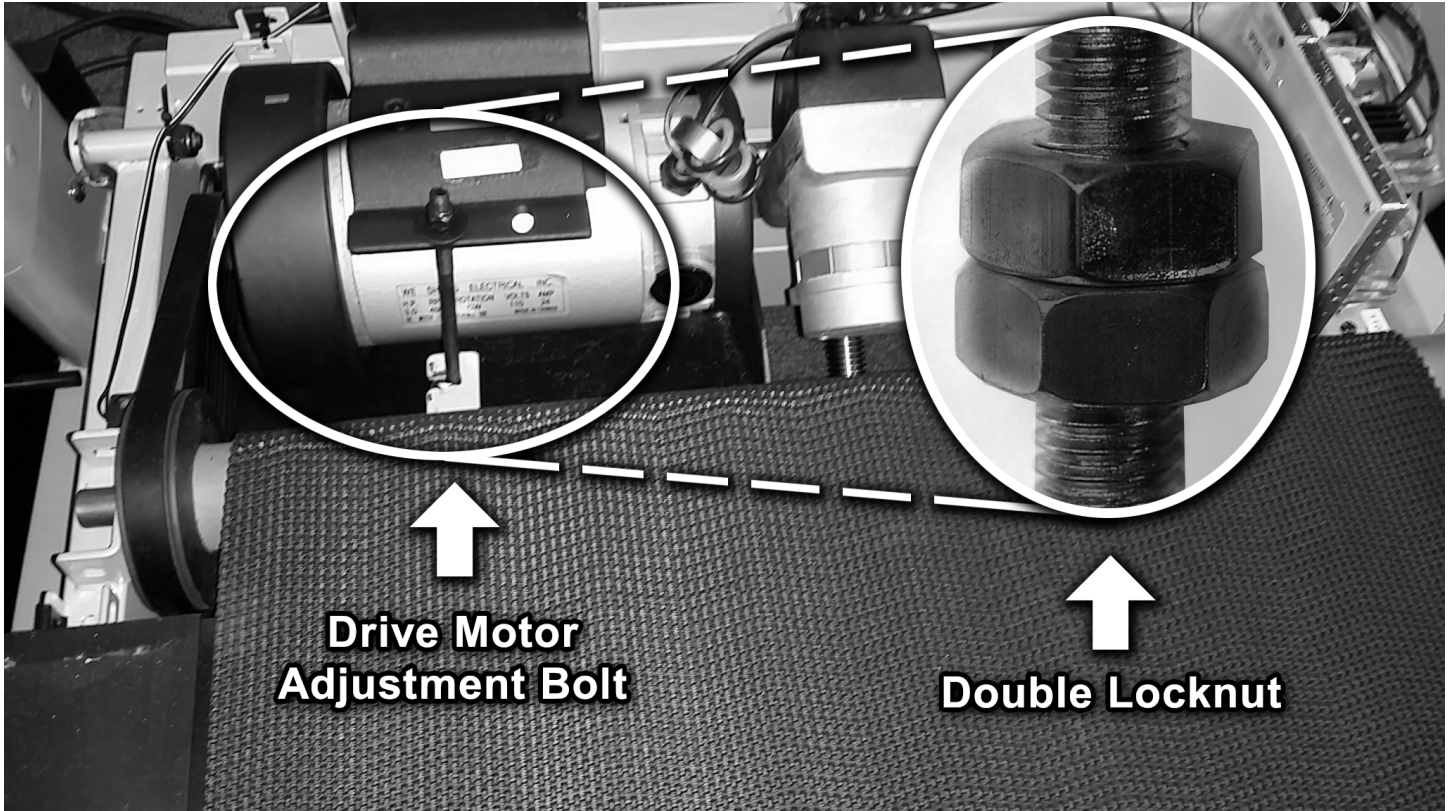

### Treadmill Belt Slipping?

**IMPORTANT: DO NOT OVER TIGHTEN THE TREADMILL BELT! THIS WILL VOID YOUR BELT WARRANTY!**

The circled image above is the drive motor adjustment bolt. **If you have tried to adjust the rear rollers and the belt is still slipping then this bolt will need to be tightened.** This is a one-time adjustment and will never need to be adjusted again. Here are the instructions on how to tighten this bolt:

Elevate your treadmill to the highest possible elevation. Remove the (4) Phillip screws located in the motor cover. You will now be able to see and adjust the drive motor adjustment bolt.

This is very important: If you have already tried to adjust the rear roller bolts (which most likely you have) then it is very important to loosen the rear roller bolts by the same amount of turns you previously tightened them. If you are not sure, call us at 888-888-7985 (Ext 1) and we will walk you through this step. Or, you should be able to see about a 1/2" gap in-between the rear roller and the plastic end cap covering the roller. Again, at any point you can call us directly at 888-888-7985 (Ext 1).

The next step is to tighten the drive motor adjustment bolt. If it feels really loose then you can tighten it to the point where you can no longer wiggle it with your hand. From here, you will tighten the bolt 1/4 turn clockwise and then walk on the treadmill to see if the slippage is gone. If it is not then tighten the bolt another 1/4 turn clockwise. Keep repeating this to the point that the belt is no longer slipping. You do not want to over tighten the belt. Once the belt is no longer slipping you can put the motor cover back on and lower the treadmill incline back down to 0%. Walk on the treadmill again. There is a slight chance that the belt will slip and that is ok. Now you can proceed with the normal belt adjustment rules listed on the previous page. Again, you will never have to adjust the motor drive adjustment bolt again.

## CARE & MAINTENANCE

**WARNING!** To prevent electrical shock, be certain the treadmill is turned off and unplugged before cleaning and routine maintenance.

### RUNNING BELT AND RUNNING DECK LUBRICATION

For maximum treadmill life, this treadmill needs routine lubrication as part of a general maintenance for the machine. The routine maintenance procedure will prevent premature wear of the running belt, running deck and drive motor system.

The recommended lubrication schedule as:

<i>USAGE</i>	<i>LUBRICATION</i>
Walking	Every 8 - 10 months
Jogging	Every 6 Months
Running	Every 4 months
Commercial	Every Month



Lubricant for running deck

The above lubrication schedule is the recommended application for a single user, 30 - 45 minutes per workout, 3-4 times per week. For lubrication, you can contact your dealer. Use only 100% pure liquid silicone.

### FLOOR MATS – EXERCISE MATS:

If you plan to place this treadmill on a stone, tile, concrete, wood, vinyl, laminate or any other hard surface, it is highly recommended to place a treadmill mat underneath. This will prevent excess dust from building up underneath the treadmill and the motor compartment and it will help to cut down on vibrations and noise. Use 36" x 78" size mat or larger.

### CLEANING

Perspiration should be wiped from the console and treadmill surface after your workout. You should wipe down your treadmill once a week with a water dampened, soft cloth. Be careful not get excessive moisture on the display panel as this might cause an electrical shock or failure. Every 6 months, open up the motor cover and vacuum inside to remove any type of dust, lint or pet hair that has accumulated. Vacuum around your treadmill as often as needed. These preventative maintenance steps can add significant life to your treadmill!

### STORAGE

Store your treadmill in a clean and dry environment. Ensure the master power switch is off and is unplugged from the electrical wall outlet when not in use.

### MOVING

This treadmill has been designed and equipped with wheels for moving. Before moving, ensure the master power switch is in the off position and the power cord is unplugged from the electrical outlet. Elevate your treadmill to 6% as this will make it easier to move. CAUTION: This treadmill is very heavy so please practice common sense while attempting to move your machine!

## LUBRICATION MAINTENANCE

### LUBRICATION MAINTENANCE:

It is important to take good care of your treadmill deck (the walking surface underneath the belt). Using a 100% pure silicone lubrication will also improve the performance of your treadmill by reducing the heat and friction that occur during workouts.

**NOTE:** Use the silicone that is supplied with the treadmill. Additional silicone lubricant can be purchased from your retail store.

**WARNING:** STOP the treadmill and remove the safety key before lubricating the running deck.

### HOW TO APPLY SILICONE ONTO THE TREADMILL DECK:

1. Locate the silicone bottle. It is located in the hardware kit package included with this treadmill.
2. Cut the very tip of the applicator shaft with a pair of scissors.
3. Apply the silicone evenly on the treadmill deck as the drawing shows. The application area is only in the area where your feet make contact with the deck. This typically is the middle 2/3rds of the deck area. Do not put too much silicone on the deck. To apply the silicone, lift the belt up with your fingers and reach the silicone bottle as far underneath the belt as you can and squeeze a small amount onto the deck. Repeat the same procedure from the opposite side of the belt to reach the other portion of the deck. Slowly work your way down the treadmill deck. You only need to apply a little lubrication in each spot. After completing the lubrication, it is recommended to now do a workout as the heat and friction from the belt will help spread the lubrication around to the rest of the deck area and absorb into the underside of the belt.

**CAUTION:** Excessive lubricant may cause the silicone to leak onto the floor and may make the treadmill belt slippery.

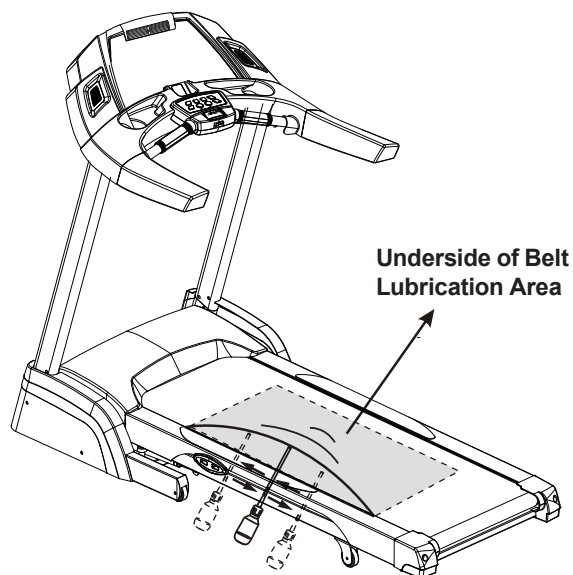

## TROUBLE SHOOTING GUIDE

### SYMPTOM:

#### No Power or Lights on the upper console

### SOLUTION:

Check the power toggle switch and make sure it is turned on. Also, check to make sure that the power cord is fully inserted into the base of the treadmill. Check to make sure the Fuse (near the power toggle switch) has not “tripped”. If it has “tripped” try pressing it back into place. Turn the treadmill off and then turn it back on again and check for power.

---

### SYMPTOM:

#### LED Display lights flicker or flash on and off

### SOLUTION:

The electrical system is experiencing an issue. Contact a service technician for a service call.

---

### SYMPTOM:

#### Display reads: SPEED ERROR

### SOLUTION:

1. Turn off the power to the unit.
  2. Wait 5 seconds and turn power back on again.
  3. Press the “START” button on the console.
  4. If “SPEED ERROR” Displays again, try:
    - 4.1 Check that both ends of the power cord are secured firmly to the outlet and the unit.
    - 4.2 If you are using an extension cord or power strip remove it and plug the unit directly into an outlet.
    - 4.3 Check the treadmill’s belt tension, is it too tight? Loosen the belt slightly (see belt adjustment section).
    - 4.4 Check if the treadmill need lubrication (see care and maintenance section).
    - 4.5 If treadmill belt runs for 10sec and displays “ERROR” again after checking all of the above items contact a service technician for a service call.
- 

### SYMPTOM:

#### Display reads: INCLINE ERROR

### SOLUTION:

1. Turn off the power to the unit.
2. Wait 5 seconds and turn power back on again.
3. Press the “START” button on the console.
4. Press the red “EMERGENCY STOP” button as soon as the belt starts moving.
5. Press Incline Up (^) , Incline Down (v), and MODE all at the same time to enter the engineering mode.
6. An incline number will display between 30-230, if the number is above 50 contact a service technician for a service call.
7. Press STOP to exit engineering mode, Reset the EMERGENCY STOP button. Press the “START” button.
8. Press Incline Up (^) or Incline Down (v) to see if the incline is working properly. If it is not working contact a service technician for a service call.

\*To improve the life of your treadmill and avoid unnecessary repairs, perform regular preventive maintenance. Refer to care and maintenance, belt lubrication, and belt adjustment section of the manual for preventative maintenance instructions.

## PARTS LIST

ITEM	DESCRIPTION	QTY	ITEM	DESCRIPTION	QTY
AB1	ST29-AB1 Main frame	1	H06	ST12-H10 Hear rate PCB	1
B20	ST82-B21 Rubber cushion	2	H07	ST77-H07 Hand pulse	2
B21	ST08-B21 Rubber cushion	8	H09	ST77-H09 Loudspeaker	2
B22	ST32-B22 Running belt	1	H11	ST01-H11 Upper console wire	1
B23	ST82-B23 Side Rail	2	H13	ST77-H13 Fan	1
B24	ST82-B24 Upper motor cover	1	H15	ST11-H31 Expansive monitor	1
B25	ST10-B25 Lower motor cover	1	H16	ST77-H16 Membrane key(H16)	2
B26	ST82-B26 Roller cover,left	1	AH1	ST77-AH1 Safety key set	1
B27	ST01-B27 Mobile wheel	2	H24	ST77-H24 Safety key wire	1
B28	ST25-B28 End cap, main frame	2	H28	ST79-H28 Upper controller console	1
B33	ST82-B33 Roller cover, right	1	H29	ST79-H29 Down controller console	1
B39	ST29-B46 Running deck	1	H30	ST77-H30 Controller PCB - 8key	1
B41	ST82-B41 Anti-slip pad	1	H31	ST77-H31 PCB wire A	1
B45	ST29-B45 Supporting tube	1	H32	ST79-H32 Cross-flow fan fixing plate	1
AC1	ST85-AC1 Base frame	1	H35	ST79-H35 Loudspeaker cover - Left	1
C11	ST03-C11 Foot step	1	H36	ST79-H36 Loudspeaker cover - Right	1
C13	ST08-C13 Mobile wheel housing	2	H37	ST79-H37 Rubber	1
C14	ST01-C14 Mobile wheel, base frame	2	H38	ST79-H38 Sheet pad	1
C16	ST01-C16 Pad, base frame	4	H40	ST79-H40 Switch ( START )	1
C18	ST01-C18 Spring, foot step	1	H41	ST79-H41 Switch	2
C22	ST85-C22 Protective cover, left	1	H42	ST77-H42 PCB(safety key)	1
C23	ST85-C23 Protective cover, right	1	H43	ST79-H43 Overlay, console	1
C28	ST25-C28 Rotary bracket	2	H44	ST79-H44 Wire protective sleeve UC-0.5	2
C29	ST27-B27 Wheel	2	J01	ST29-J01 Motor	1
AE1	ST14-AE1 Fixing arm, folding	1	J02	ST04-J02 Incline motor	1
E04	ST06-E04 Air shock	1	J03	ST79-J03 Controller	1
E07	ST03-E07 Rubber bush	1	J08	ST01-J08 Wire, montor sensor	1
AD1	ST14-AD1 Lift arm, incline	1	J09	EL010109A Power cord	1
D03	ST14-D03 Bush, base frame	2	J13	ST03-J13 Grounded wire	1
AF1	ST79-AF1 Console frame	1	J15	ST03-J15 Lower console wire	1
AF2	ST85-AF2 Handlebar left frame	1	J16	ST08-J16 Socket	1
AF3	ST85-AF3 Handlebar right frame	1	J17	ST06-J17 On/off switch	1
F08	ST03-F08 Wire, hand pulse	1	J18	ST06-J18 Breaker	1
AG1	ST85-AG1 Console mast, left	1	J22	ST08-J22 Fixing bracket,controller	1
AG2	ST85-AG2 Console mast, right	1	J23	ST01-J23 Wave filter	1
H01	ST79-H01 Upper console case	1	J28	ST01-J28 Wave filter housing	1
H02	ST79-H02 Lower console case	1	K01	ST34-K01 Front roller	1
H03	ST79-H03 Wind direction adjuster	1	K02	ST25-K02 Rear roller	1
H04	ST79-H04 Overlay, console	1	K03	ST08-K03 Drive belt	1
H05	ST79-H08 Monitor	1			



## PARTS LIST - BOLTS

ITEM	DESCRIPTION	QTY	ITEM	DESCRIPTION	QTY
<b>AB</b>	<b>Bolt M10 x 40</b>			MP3 player	2
	Incline Motor	1		Controller PCB - 8key	5
<b>AC</b>	<b>Nylon Nut M10</b>			Safety key set	4
	Incline Motor	2		Switch (start, speed)	6
	Lift Arm	4		Switch (speed, incline)	12
<b>AD</b>	<b>BOLT M8 x 140mm</b>		<b>AY</b>	<b>Washer M6</b>	
	Motor	1		Front & rear roller	3
<b>AG</b>	<b>Nylon Nut M8</b>		<b>ATE</b>	<b>Bolt M8 x 50mm</b>	
	Motor	2		Foot step	1
<b>AGE</b>	<b>Nylon Nut M8</b>			Mobile wheel	2
	Air Shock	2		Rotary bracket	2
	Fixing Arm, Folding	1	<b>BB</b>	<b>Screw 4 x 15mm</b>	
	Mobile Wheel	2		Grounded wire	1
	Foot Step	1		Console contronller case	1
	Mobile Wheel Housing	2		Console	1
	Rotary Bracket	4	<b>BN</b>	<b>Bolt M10 x 60mm</b>	
<b>AH</b>	<b>Washer M8</b>			Incline motor	1
	Motor	1		Fixing arm, incline	2
<b>AI</b>	<b>Nut M4</b>		<b>BP</b>	<b>Bolt copper column M3 x 10</b>	
	Upper Motor Cover	4		Wave filter	4
<b>AJ</b>	<b>Self Tapping Screw 4 x 15mm</b>		<b>BQ</b>	<b>Bolt M3 x 6mm</b>	
	EZ-Button	6		Wave filter	4
	Upper Motor Cover	4	<b>BW</b>	<b>Screw 3 x 25</b>	
	Console Frame	6		Hand pulse	4
	Console Controller Case	4	<b>CJ</b>	<b>Bolt M8 x 115MM</b>	
	Controller	2		Motor	1
	Fixing Bracket, Controller	2	<b>CK</b>	<b>Screw 6 x 15 w/U Shape Washer</b>	
	Upper & Lower Console Case	17		Deck	2
	Rotary Bracket	4	<b>CO</b>	<b>Bolt M6 x 65mm</b>	
	Wire Protective Sleeve UC - 0.5	2		Front & Rear Roller	3
	Fixing Bracket, Fan	4	<b>CP</b>	<b>Bolt 6 x 25mm w/Washer</b>	
<b>ALE</b>	<b>Bolt M8 x 40mm</b>			Running Deck	8
	Lift Arm, Folding	1	<b>SB1</b>	<b>Bolt M10 x 40</b>	
	Rear Mobile Wheel	2		Fixing Arm, Folding	2
	Rotary Bracket	2	<b>FQ</b>	<b>Screw 5 x 25mm</b>	
<b>AO</b>	<b>Self Tapping Screw 3 x 10mm</b>			Supporting Tube	2
	Loud Speaker	4	<b>EL</b>	<b>Bolt M8 x 30</b>	
	Socket	2		Air Shock	2
<b>AR</b>	<b>Self Tapping Screw M4 x 10mm</b>		<b>HARDWARE KIT</b>		
	Lower Motor Cover	4	<b>DF</b>	<b>Screw 4 x 10mm</b>	
	Left, Right Roller Cover	2		Side Cover, Right & Left	4
<b>AS</b>	<b>Bolt M8 x 15mm</b>		<b>ASE</b>	<b>Bolt M8 x 15mm</b>	
	Pad, Base Frame	4		Console Mast + Handlebar	14
<b>AX</b>	<b>Screw 3 x 10mm</b>		<b>AL</b>	<b>Bolt M8 x 40mm</b>	
	Sensor	2		Handlebar	4
<b>AX</b>	<b>Screw 3 x 6mm</b>				
	Monitor	10			
	Fan	4			

**EXPLODED DRAWING**

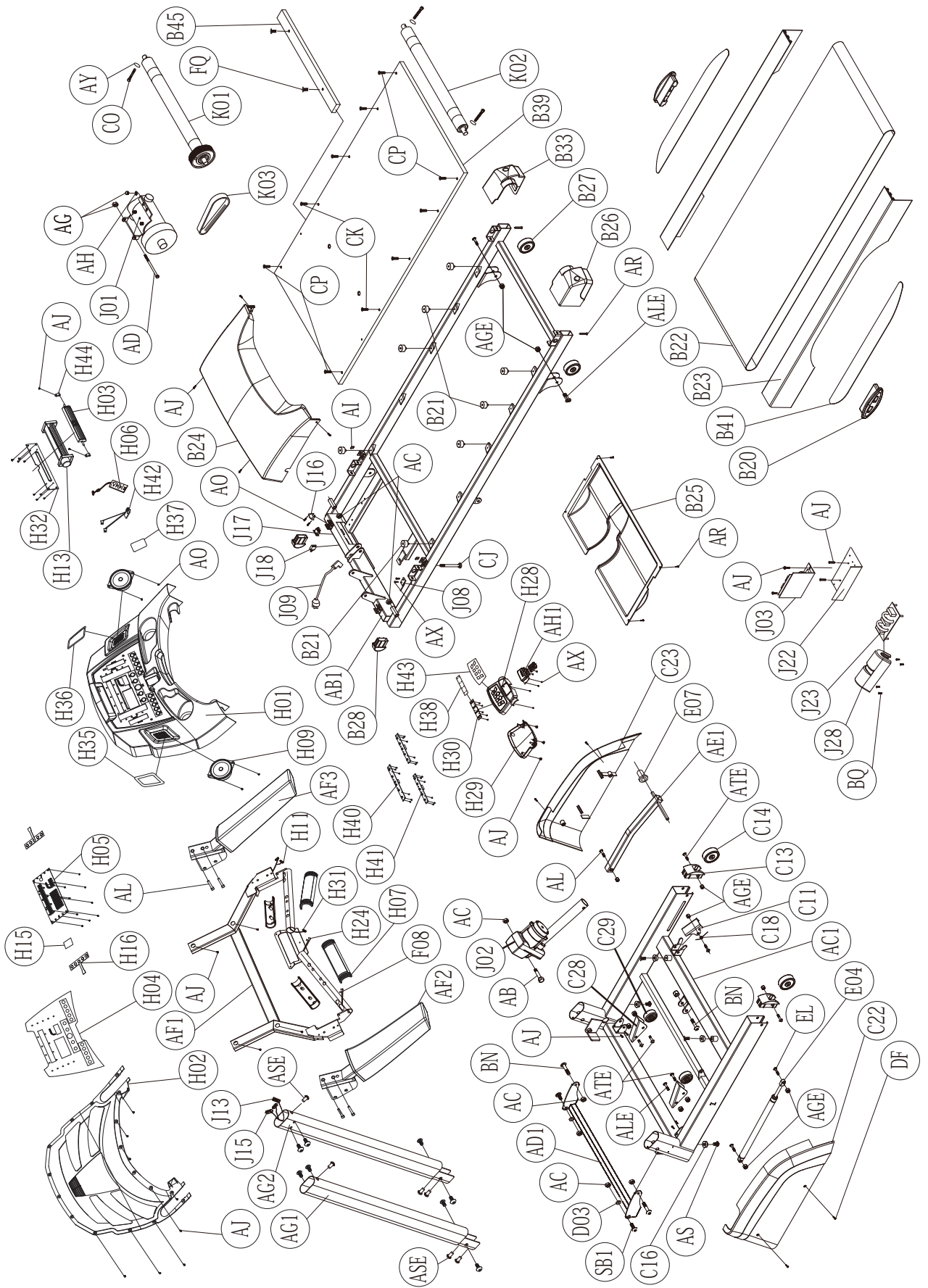

## WARRANTY INFORMATION

### 3G Cardio Pro Runner Treadmill Warranty

What does this warranty cover? This warranty covers your 3G Cardio Pro Runner Treadmill against defects in material and workmanship when used for the purpose intended, under normal conditions, and provided it receives proper care and maintenance.

How long does the coverage last? Warranty starts from the date of purchase and is as follows:

**Residential Warranty: Lifetime motor, lifetime frame, 5 years parts, 1 year in-home labor.**

Model	Labor	Parts	Max User Weight	Daily Usage	Voltage
Pro Runner	1 Year	5 Years	350lbs	Up to 4 hours	15 amp 110v Outlet

**\*Light Commercial Warranty: 3G Cardio Pro Runner Treadmill is NOT WARRANTIED for any type of commercial use.**

Model	Labor	Parts	Max User Weight	Daily Usage	Voltage Required
Pro Runner	N/A	N/A	N/A	N/A	15 amp 110v Outlet

\*A 3G Cardio product is placed into a location with a business address and therefore not a residential setting.

What will 3G Cardio do? 3G Cardio's manufacturer warranty will provide a replacement part and/or service at no charge for any part found defective in workmanship or materials during the warranty period.

How do you get service? In order to obtain replacement parts or service as provided by this warranty, please call the location where you purchased the treadmill. You may also call 3G Cardio (1-888-888-7985) Monday through Friday 9:00 a.m. to 5:00 p.m. Arizona time. Ask to speak to the service department and please have your serial number, date of purchase, original bill of sale and location of purchase available.

This warranty shall not apply to a 3G Cardio Pro Runner Treadmill which is subject to misuse, neglect, accident, or unauthorized repairs and alterations. This warranty is only valid to the original owner and is non transferable if sold, traded, bartered or for any other reason of change of ownership. An original bill of sale must be made available stating the purchase date, owner's name, model and place of sale in order to validate warranty. No exceptions will be made otherwise. All other obligations or liabilities, including liability for consequential damages, are hereby excluded. All of the parts for the 3G Cardio Pro Runner Treadmill can be ordered from 3G Cardio, 14647 So. 50th Street #110, Phoenix, Arizona 85044. Parts will be shipped and billed at the current prices, which are subject to change without notice.

Labor is covered under the manufacturer's warranty period where there is a local 3G Cardio service provider available. For inquiries on service providers and their locations please call toll free 1-888-888-7985.

**Register your product at [www.3gcardio.com/register](http://www.3gcardio.com/register)**



3G Cardio Fitness Equipment  
14647 So. 50th Street Suite 110  
Phoenix, AZ 85044

1-888-888-7985  
[www.3GCardio.com](http://www.3GCardio.com)