



ELITE UB X

Owner's Manual



Questions? Call 888-888-7985

3G Cardio • 14647 So. 50th St. Suite 110 • Phoenix, AZ 85044

IMPORTANT! PLEASE READ:

MISSING ITEMS?

Before throwing away packaging, please inspect Styrofoam to ensure all parts have been removed. Some parts are harder to find! Turn Styrofoam upside down and inspect from all angles before discarding.

If you purchased your 3G Cardio product from an online retailer (3GCardio.com, Amazon, Costco etc..) and need help or have questions, comments or concerns, please call or email us (3G Cardio) directly. We are not operators, we are experienced fitness professionals and can help you with anything and everything!

If you purchased your 3G Cardio product from a “brick and mortar” retail store, feel free to contact the store directly with any questions or concerns. You are still more than welcome to contact us too!



3G Cardio Fitness Equipment
14647 So. 50th Street Suite 110
Phoenix, AZ 85044

1-888-888-7985
www.3GCardio.com
support@3gcardio.com

© Copyright 3G Cardio LLC
All Rights Reserved



Questions? Call 888-888-7985

3G Cardio • 14647 So. 50th St. Suite 110 • Phoenix, AZ 85044

Table of Contents

Welcome to 3G Cardio!	1
Safety Warnings and Precautions	2
Heart Rate and Exercise Preparations	3
Warm Up / Cool Down	4
Hardware List	5
Bike Assembly	6-10
Moving Your Exercise Bike:	10
Programming Your Exercise Bike	
Button and Display Functions	11-12
Pre-Programmed Workouts	13-16
Heart Rate Control Programs	17
Constant Watts Programs	18
Recovery Program	18
Unit of Measure Adjustment	19
Bluetooth® Connectivity	20-21
Bluetooth® Software Update	22
Maintenance	23
Exploded Diagram	24
Parts List	25
Warranty	26

Welcome to the 3G Cardio Family!

We are a highly experienced team of health and fitness equipment experts with over fifty years experience in the health and fitness industry. Our two main goals are to offer outstanding exercise equipment and to provide the best customer service experience possible.

We understand that you have many choices when it comes to fitness equipment. We know that our continued success is based upon the quality of the products we deliver and the client support we provide.

We will never cut corners to save money and we will always exceed your expectations!

If you ever have questions, problems or concerns, please contact us right away. We are fantastic at what we do and we would love a chance to prove it to you.

3G Cardio Family

1-888-888-7985

Support@3GCardio.com

SAFETY WARNING

- Read and understand owner's manual thoroughly.
- Consult with a physician prior to using this machine.
- Misuse of this machine may result in injury.
- Do not allow children or pets on or around this machine.
- Always use this machine on a level surface.
- Keep body and clothing free and clear of all moving parts.
- Heart rate readings are for reference only and may be inaccurate.
- This product is not intended for medical purposes.
- Replace warning label if damaged, missing or illegible.

IMPORTANT: Read all instructions and warnings before using this bike.

IMPORTANT VOLTAGE INFORMATION! Before plugging the power cord into an electrical outlet, verify that the voltage requirements for your area match the voltage of the bike that you have received. The power requirements for this bike are: Input: 100v 240V 50/60H

GROUNDING INSTRUCTIONS: This bike must be grounded. If it should malfunction or break down, grounding provides a path of least resistance for electric current to reduce the risk of electric shock. The plug must be plugged into an appropriate outlet that is properly installed and grounded in accordance with all local codes and ordinances.

DANGER! Improper connection of the equipment-grounding conductor can result in a risk of electric shock. Check with a qualified electrician or service provider if you are in doubt as to whether the bike is properly grounded.

CONSULT A PHYSICIAN IMMEDIATELY! Warning: Before starting any exercise program consult your physician. This is especially important for individuals over the age of 35 or persons with preexisting health problems. Read all instructions before using any fitness equipment. 3G Cardio LLC assumes no responsibility for personal injury or damage sustained by or through the use of this bike.

IMPORTANT SAFETY INSTRUCTIONS:

- Obtain a medical exam before beginning any exercise program.
- Keep children and pets away from the bike. Teenagers and disabled persons must be supervised while using the bike.
- Stop exercising if you feel faint, dizzy, or experience pain at any time while exercising and consult your physician.
- Disconnect all power before servicing this bike.
- Connect the bike to a properly grounded outlet only. • Do not operate this machine in damp or wet locations.
- Inspect the bike for worn or loose components and bolts before each use.
- Do not operate the bike if: 1) The power cord is damaged. 2) The bike is not working properly. 3) The bike has been dropped or damaged.
- Do not use this bike outdoors.
- Read and understand this owner's manual completely before using the bike.
- Read and understand all warnings posted on the bike and in this owner's manual.
- Do not wear loose or dangling clothing while using the bike.
- Always wear proper footwear on or around exercise equipment.
- Set up and operate the bike on a solid, level surface.
- Modifying this bike in any way will void all 3G Cardio warranties.

HEART RATE INFORMATION

TARGET HEART RATE ZONE

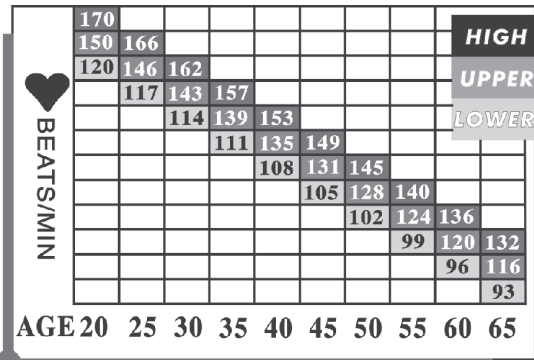

Target Heart Rate Zone
 $220 - \text{Your Age} = \text{Maximum Heart Zone}$

You do not want to workout at your maximum heart rate. The recommended Heart Rate Zone is a percentage of your maximum heart rate. Between 60% and 75% of your maximum heart rate.

Lower limit of Target Heart Rate Zone = Maximum heart rate X 0.6

Upper limit of Target Heart Rate Zone = Maximum heart rate X 0.75

HOW OFTEN SHOULD YOU EXERCISE?

You should exercise three to four times a week, 30 minutes per workout, or as instructed by your doctor.

HOW HARD SHOULD YOU EXERCISE?

Intensity of exercise is reflected in your heart rate. Exercise must be sufficiently rigorous to strengthen your heart muscle and condition your cardiovascular system. Before starting any exercise program consult your physician.

HOW LONG SHOULD YOU EXERCISE?

Sustained exercise conditions your heart, lungs and muscles. The longer you are able to sustain exercise within your target heart range, the greater the aerobic benefits. You should always begin a workout with at least a 5 minute warm up at low intensity.

If you have any known heart / cardiovascular issues you must consult with your doctor to find out if you are healthy enough for exercise.

Beginner Program

	Exertion Level	Duration
Week 1	Easy	6 – 12 Minutes
Week 2	Easy	10 – 16 Minutes
Week 3	Moderate	14 – 20 Minutes
Week 4	Moderate	18 – 24 Minutes
Week 5	Moderate	22 – 28 Minutes
Week 6	Slightly higher or slightly lower	30 Minutes
Week 7	Add interval training	3 minutes at moderate, then 3 minutes at higher exertion, then 3 minutes at easy. Continue this pattern for 24–30 minutes.

WARM UP & COOL DOWN

A successful exercise program consists of a warm up, aerobic exercise, and a cool down. Warming up is an important part of your workout, and should begin every session. It prepares your body for more strenuous exercise by heating up and stretching out your muscles. At the end of your workout, repeat these exercises to properly cool down. We suggest the following warm up and cool down exercises:

1



Head Rolls

Rotate your head to the right for one count, feeling the stretch up the left side of your neck. Next rotate your head back for one count, stretching your chin to the ceiling and letting your mouth open. Rotate your head to the left for one count, and finally, drop your head to your chest for one count.

2



Shoulder Lifts

Lift your right shoulder up toward your ear for one count. Then lift your left shoulder up for one count as you lower your right shoulder.

3



Side Stretches

Open your arms to the side and continue lifting them until they are over your head. Reach your right arm as far upward toward the ceiling as you can for one count. Feel the stretch up your right side. Repeat this action with your left arm.

4



Inner Thigh Stretch

Sit with the soles of your feet together with your knees pointing outward. Pull your feet as close into your groin as possible. Gently push your knees toward the floor. Hold for 15 counts.

5

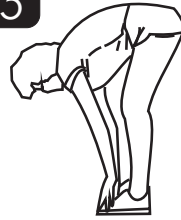

Toe Touches

Slowly bend forward from your waist, letting your back and shoulder relax as you stretch toward your toes. Reach down as far as you can and hold for 15 seconds.

6



Quadriceps Stretch

With one hand against a wall for balance, reach behind you and pull your right foot up. Bring your heel as close to your buttocks as possible. Hold for 15 counts and repeat with left foot up.

7



Hamstring Stretches

Sit with your right leg straight in front of you. Straighten your leg out while trying to hold on to your outstretched leg with your hand. Starting up with your back straight. Slowly exhale and try to bring your chest to the knee of your outstretched leg. Hold, then repeat on the other side for 15 seconds.

8



Calf / Achilles Stretch

Lean against a wall with your left leg in front of the right and your arms forward. Keep your right leg straight and the left foot on the floor; then bend the left leg and lean forward by moving your hips toward the wall. Hold, then repeat on the other side for 15 seconds.

Parts List



<p>Z Plastic Cover</p>  <p>Y Central Tube</p>  <p>N Main Frame</p> 	<p>O Rear Stabilizer</p> 
	<p>P Front Stabilizer</p> 
<p>R Handle Bar</p> 	<p>Q Saddle Support Tube</p>  <p>X Console</p> 
<p>T Seat</p> 	<p>S Pedals (S1-L) (S2-L)</p>  <p>U (U1) Bottle Holder (U2) Water Bottle</p> 
<p>Tools</p>  <p>W (W1) Screw (W2) Washer (W3) Spring Washer</p> 	<p>CHEST STRAP (TRANSMITTER)</p> 

Figure 1

Connecting The Front Stabilizer Tube

Secure the front stabilizer tube (P) with the main frame (N) by attaching bolt x2 (W1), spring washer x2 (W3) and washer x2 (W2). Tighten securely.

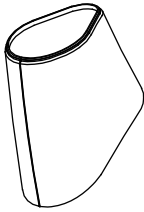
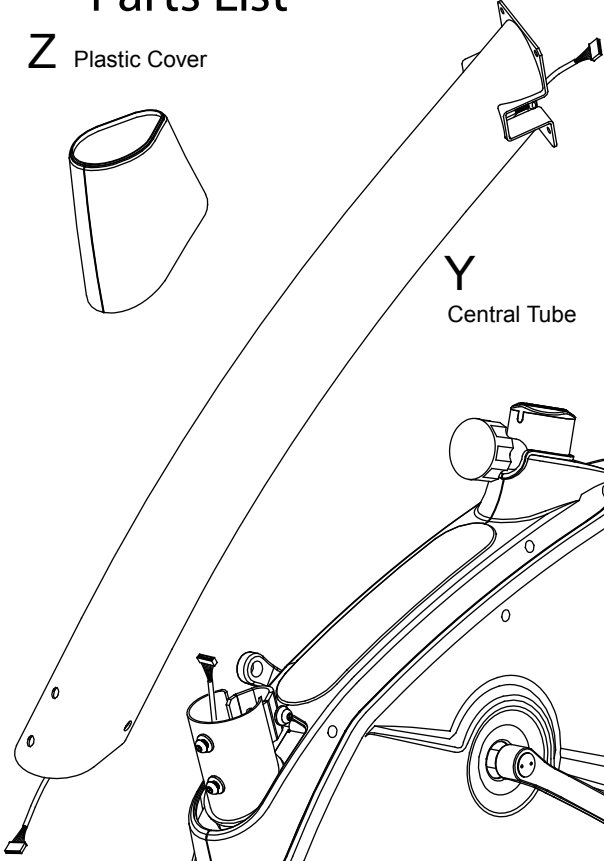
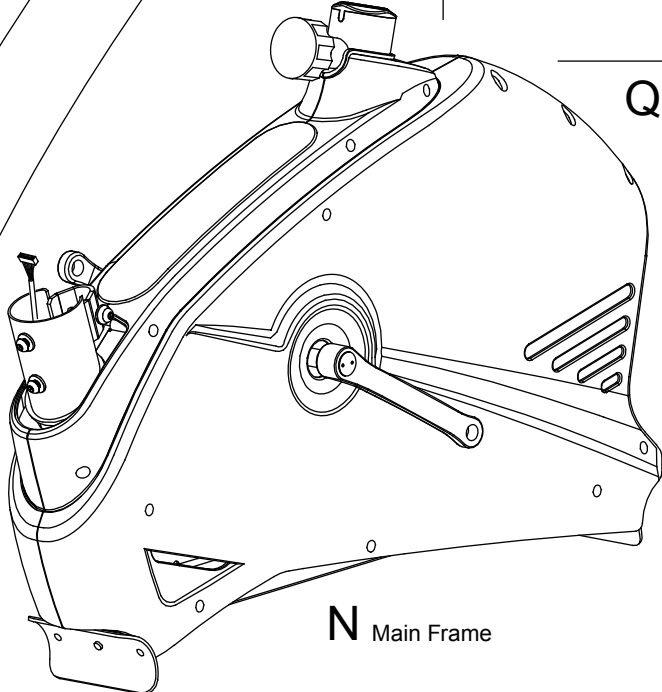
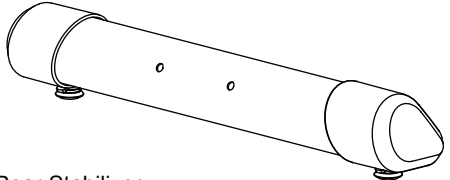
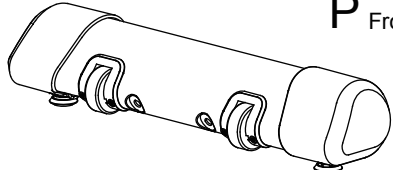
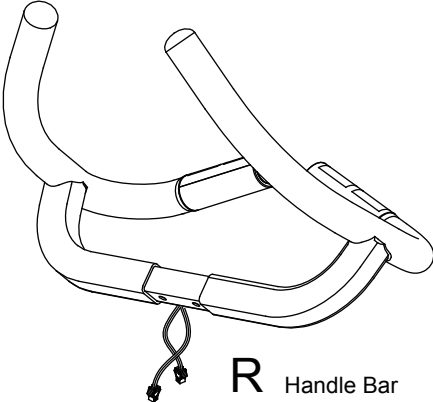
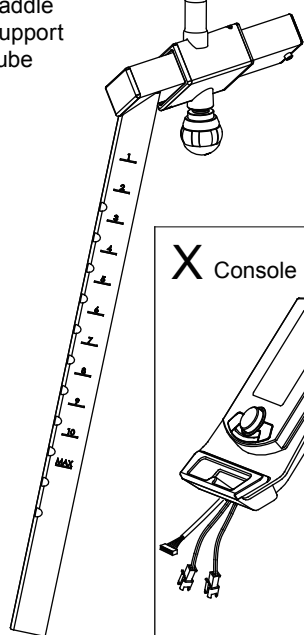
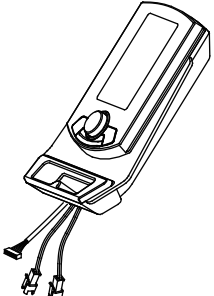
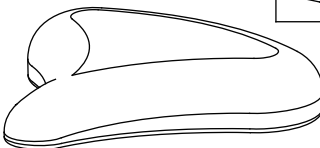
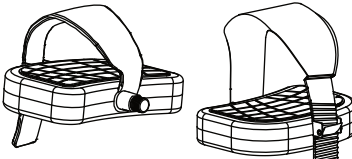
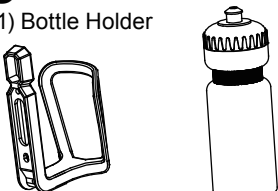
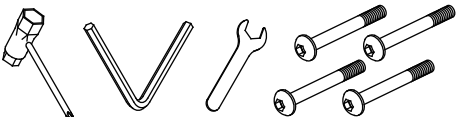
Tighten securely.

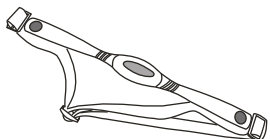
WARNING

Use correct size tool to avoid stripping bolts!

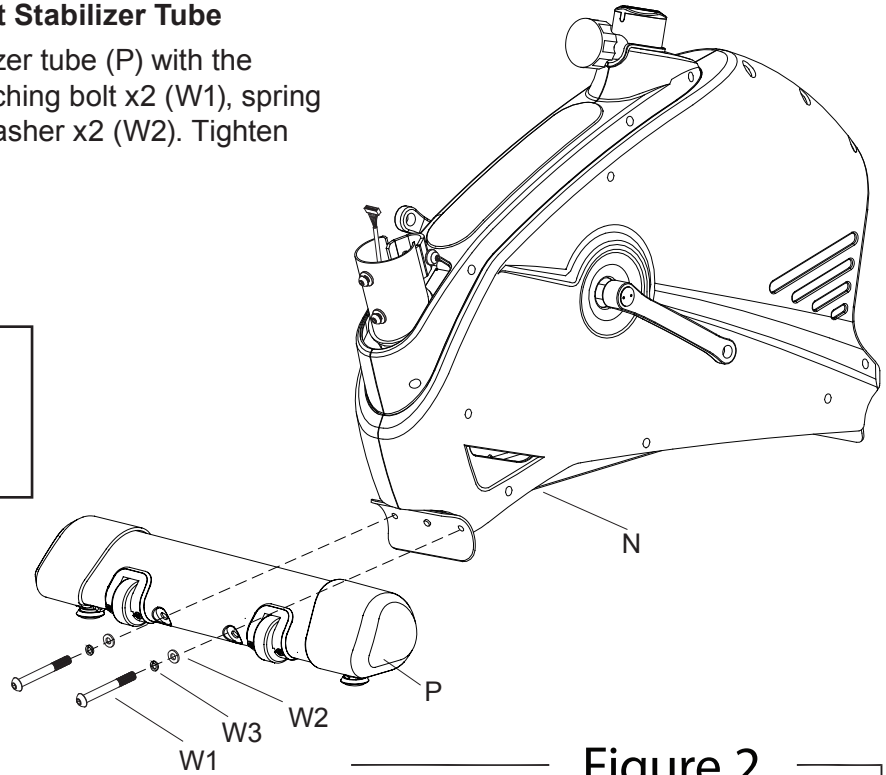

Figure 2

Connecting The Rear Stabilizer Tube

Attach the rear stabilizer tube (O) to the bracket at the back of the main frame (N). Insert bolt 2x (W1) and spring washer 2x (W3) and 2x washer (W2).

Use correct size tool to avoid stripping bolt!

Tighten securely.

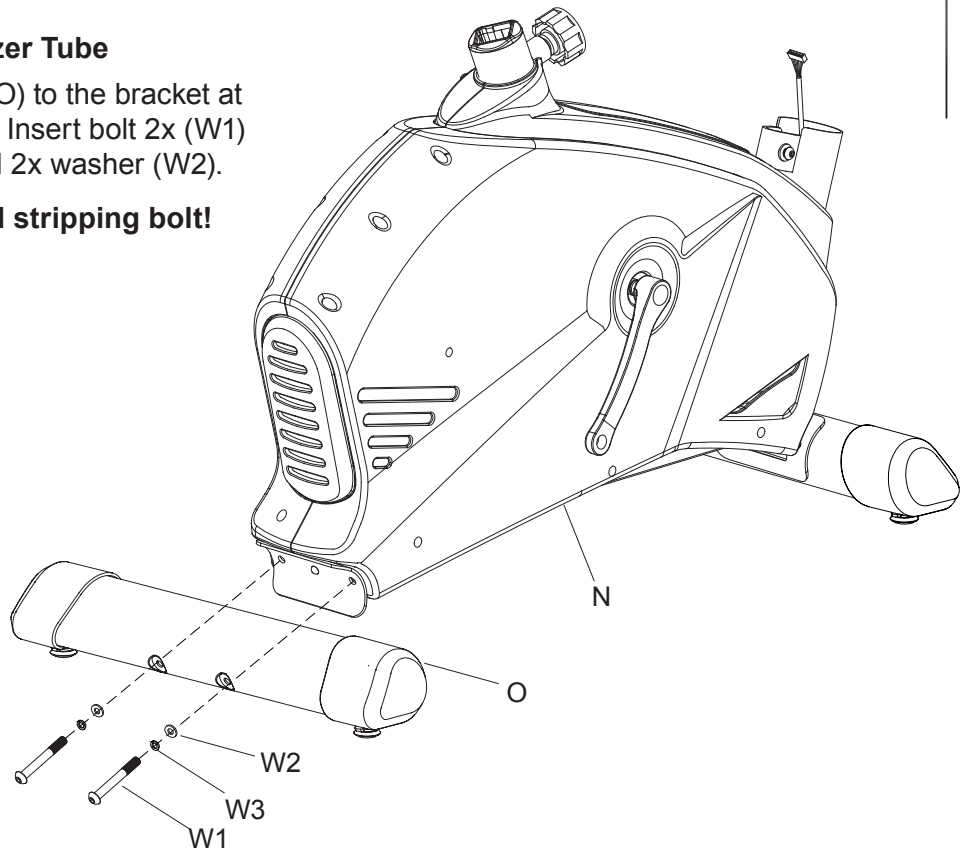

Figure 3

Assembly For Central Support Tube

STEP 1. First, remove the bolts (N5), Spring washers (N34) and washers (N4) from the main frame (N).

STEP 2. Find the Plastic Cover (Z) and slide it up the Central Support Tube (Y).

STEP 3. Connect the Sensor Wire (N7) and the Computer Cable (Y1).

STEP 4. Assemble Support Tube (Y) with the main frame (N) using bolts 3x (N5), spring washers (N34) and washers (N4).

After all bolts are inserted then tighten securely.

CAUTION: Be careful to not pinch data cables in between frame.

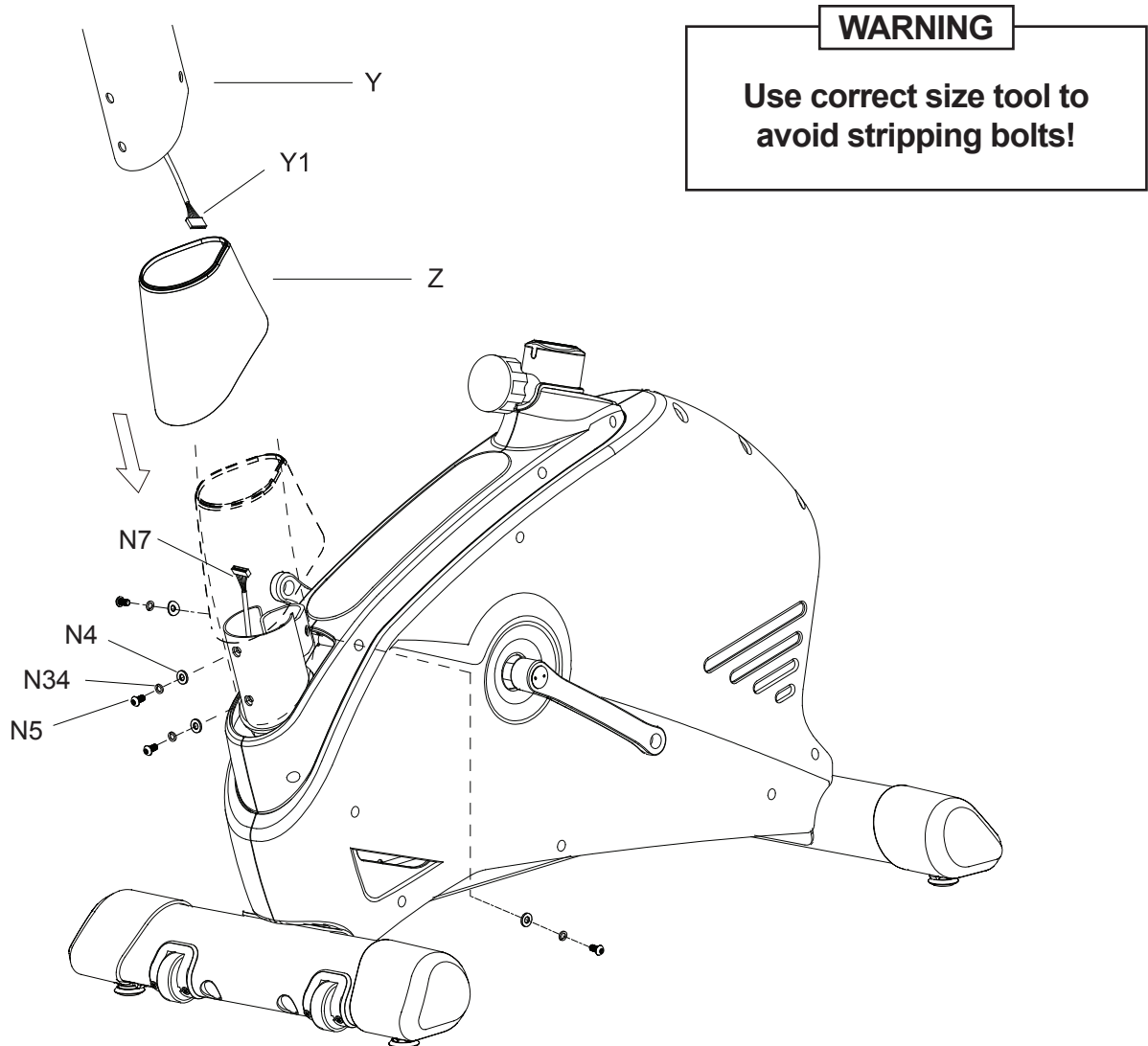

Assembly For Handle Bar

First, remove 2x nut (Y2) from the handle bar housing.

Place the handle bar (R) into the handle bar housing and secure it with 2x nuts (Y2). Prepare the sensor wires (Y1 & R3) as shown on (view A).

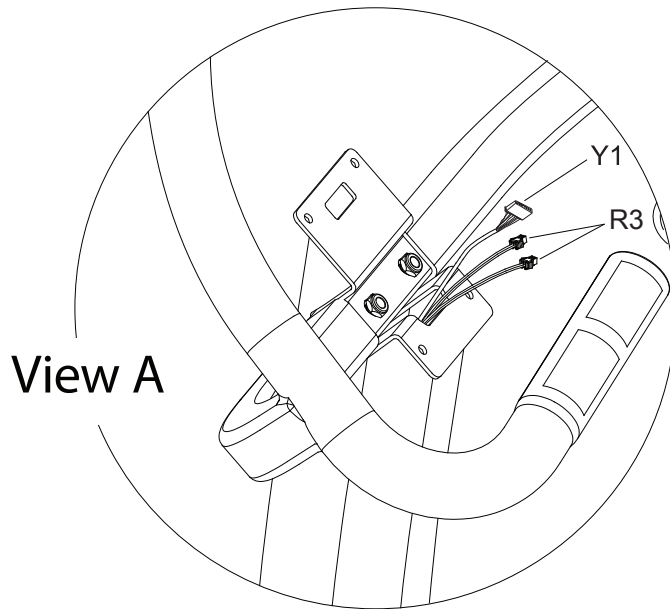

Figure 4

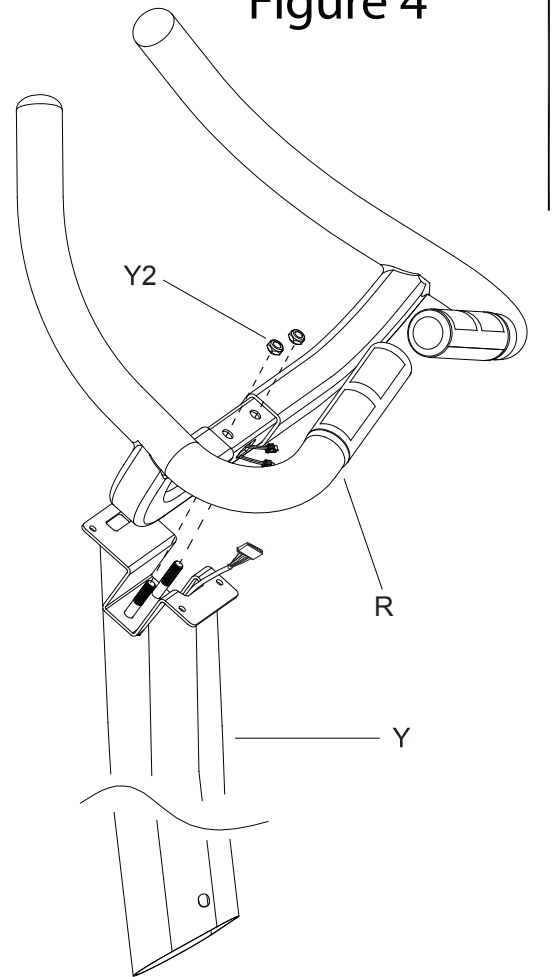

Figure 5

Assembly For Console

Remove the 4x screws from the back side of the computer (upper display).

Connect the sensor wires (R3 & Y1) with the computer wires (Z1). Place the computer onto the metal bracket (U) and tighten by using 4x screws.

DO NOT PINCH DATA CABLES!

Make sure all wires are correctly connected.

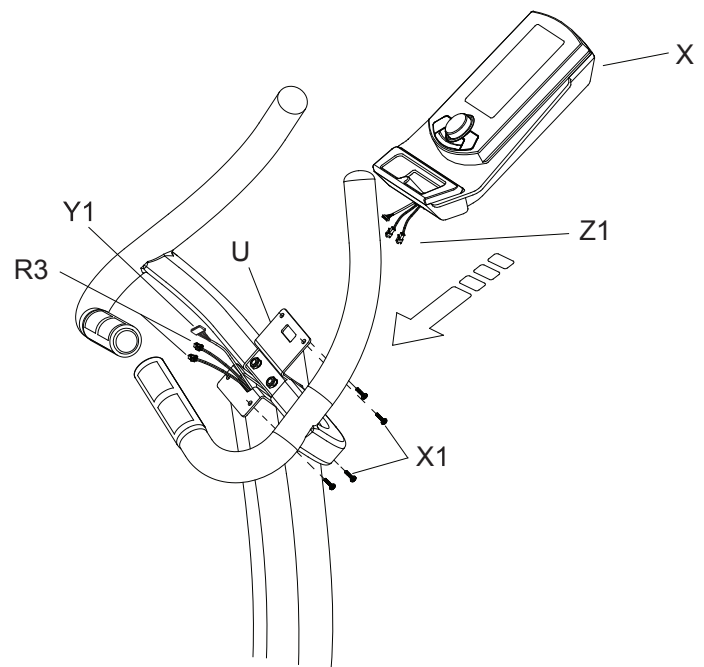

Assemble Seat Support Tube & Seat With Main Frame

STEP 1

Keep loosening knob (N22) while pulling outward until the Seat Support Tube (Q) slides into the main frame (N). Release the knob (N22) after the Seat Support Tube is fully inserted. To tighten Seat, allow Knob (N22) to set into one of the adjustment holes (Q) and then turn Knob (N22) to tighten.

WARNING

Use correct size tool to avoid stripping bolts!

STEP 2 SEAT ASSEMBLY

Install the cushion (T) directly onto the Seat Assembly Bracket (Q1). Adjust seat angle to desired position, then tighten the nuts on the left and right side of the cushion (T).

STEP 3: WATER BOTTLE HOLDER ASSEMBLY

Remove the 2x screws (U3) from the support tube (Y). Place the water bottle holder (U1) onto the Upright Support Tube (Y) and tighten with 2x screws (U3).

DO NOT OVERTIGHTEN!!

Insert the water bottle (U2) into the bottle holder (U1).

Figure 6-1

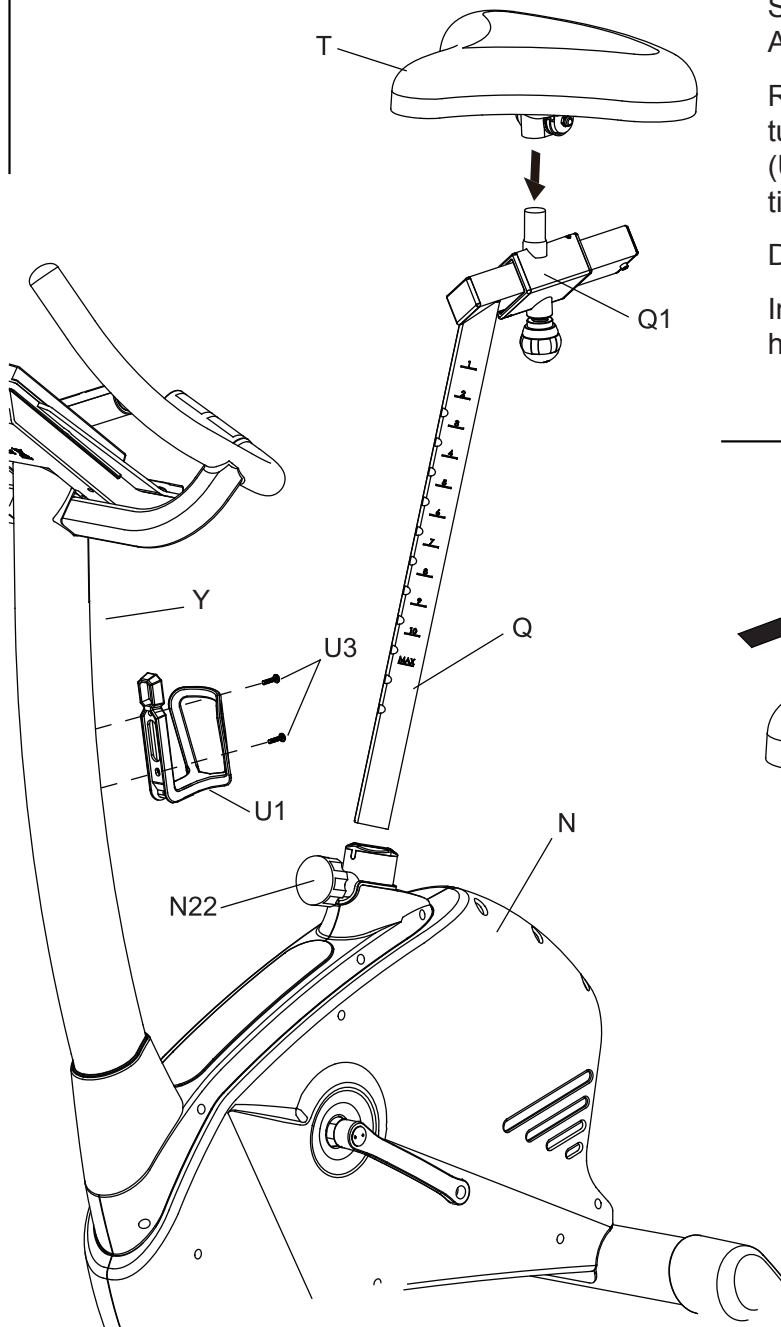
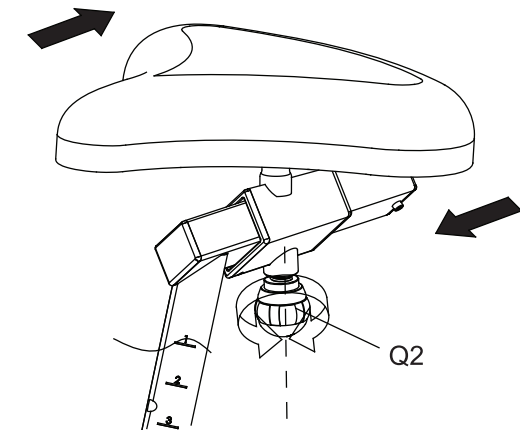

Figure 6-2



Adjust The Seat

Loosen the Seat Adjustment Handle (Q2) and move to the desired position. Tighten before use.

Figure 7

CONNECTING THE PEDALS

Attach the right pedal to user right side crank and left pedal to left crank. Pay special attention to the user left side pedal “reverse threading”. To tighten the user LEFT SIDE PEDAL, you will turn the pedal bolt “counter clockwise.”

IMPORTANT! TIGHTEN BOTH PEDALS VERY TIGHT!!!

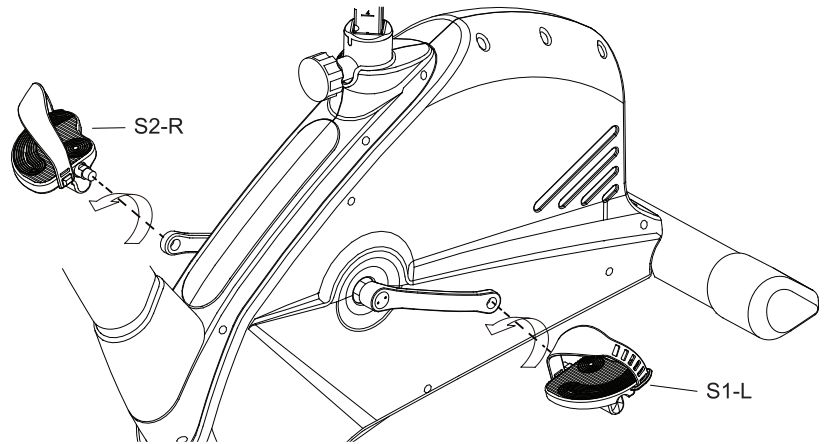

WARNING

PLEASE READ! POTENTIAL SERVICE ISSUE!

1. Pedals must be tightened very tight to crank arm. Failure to do so will result in pedal bearing failure!
2. Use correct size tool to avoid stripping bolts!

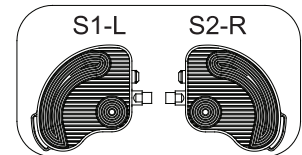

Figure 8

MOVING YOUR 3G CARDIO UPRIGHT BIKE:



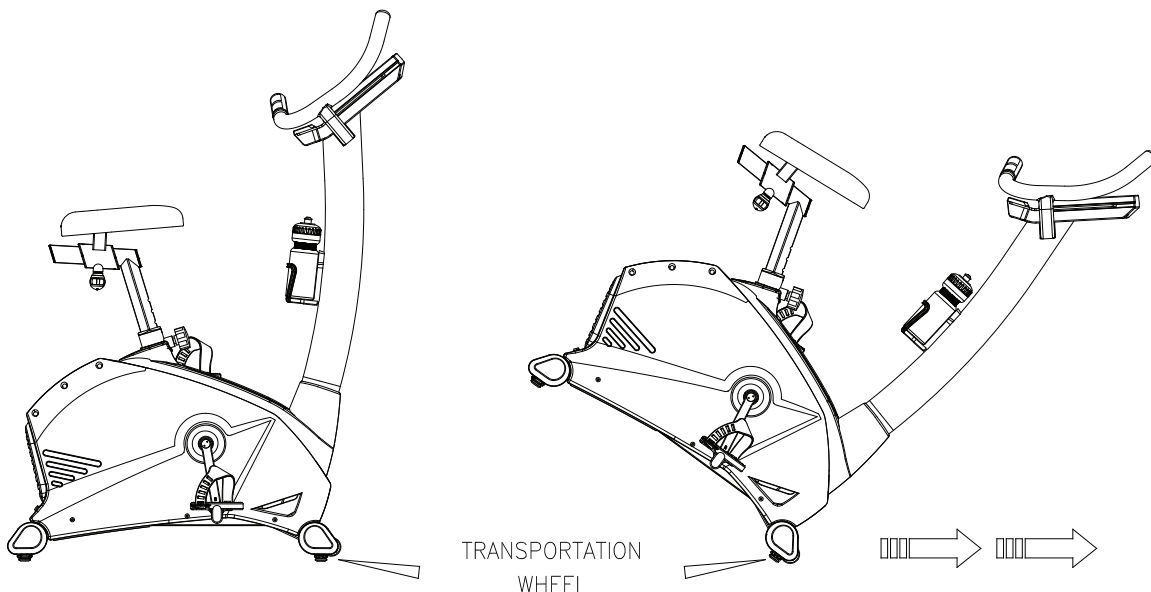

WARNING! USE CAUTION WHEN LIFTING OR ROLLING HEAVY ITEMS!

Step 1. The front stabilizer tube has built in transport wheels. Standing at the front of the bike, hold onto the top handle bars (near the upper electronics display) and pull down to tip the bike towards you. (Never pull on the actual electronics display)

Step 2. Lean the bike towards you until you have it balanced on the transport wheels. You can now move the bike around.



BUTTON FUNCTIONS

	RIGHT	To change screen data or increase training resistance levels.
	LEFT	To change screen data or decrease training resistance levels.
	ENTER	To confirm or approve settings.
	START / STOP	To start a QUICK START workout or stop a workout.
	RESET	Press the RESET button for 5 seconds to reset the electronics display to the default screen.
	RECOVERY	To activate RECOVERY function.



DISPLAY FUNCTIONS

TIME	Time will count from 00:00 to a maximum 99:00 minutes and can be set in 1 minute intervals. Time can be set to count up or down.
SPEED	Displays current training speed in MPH. Can be changed to read KPH.
RPM	Displays the Rotation Per Minute. Display range 0~100 RPM
DISTANCE	Accumulates total distance from 0 to 99.9 miles. The user may set a target distance goal by adjusting the Toggle Wheel. Each increment is 0.1 miles.
CALORIES	Accumulates an estimated caloric expenditure during training from 0 to a maximum of 999 calories. (This calorie reading is an estimate and should not be used for medical purposes and / or for the treating of any medical condition)
PULSE	User may set a desired target heart rate up to 230 BPM.
WATTS	Display current workout watts. Display range 0~999.

POWERING ON: Make sure bike is plugged in. To power on simply pedal the bike or press any button on the console. Press the RESET button for 5 seconds to return to the home screen. The LCD display will turn all console lights on and you will hear a long 2 second beep. See below (FIGURE 1 & 2).

POWERING OFF: The bike will automatically power off after 5 minutes of inactivity or press/hold the Toggle Wheel and Stop / Start at the same time for 3 seconds to shut off instantly.

- (1) Turn the Toggle Wheel to select User 1~4 and press ENTER for confirmation. (FIGURE 3~4).
- (2) Define user information for SEX, AGE, HEIGHT and WEIGHT. (FIGURE 5-8)

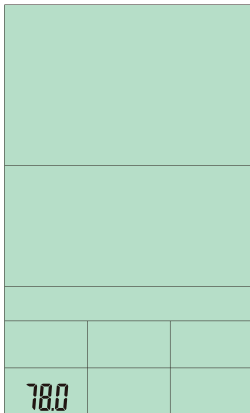

FIGURE 1

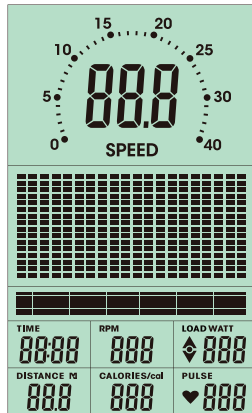

FIGURE 2

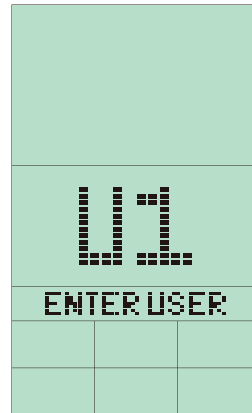

FIGURE 3

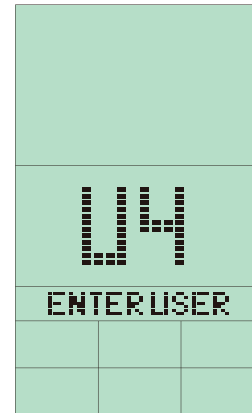

FIGURE 4



FIGURE 5

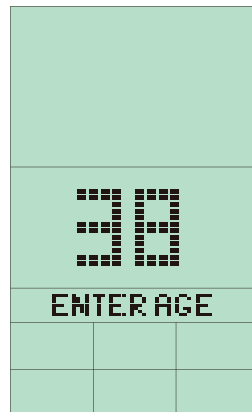

FIGURE 6

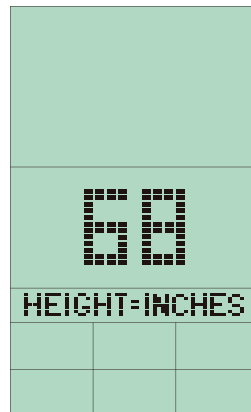

FIGURE 7

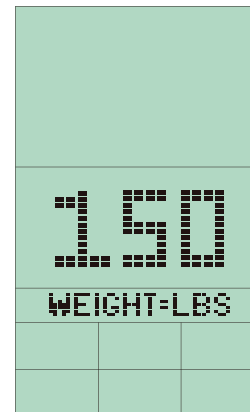
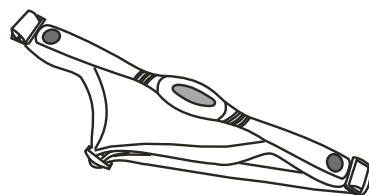

FIGURE 8

CHEST STRAP TRANSMITTER

To operate HRC, the user needs to wear the included wireless chest strap transmitter under their shirt.



CHEST STRAP (TRANSMITTER)

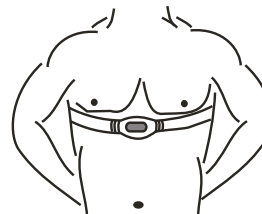

PROGRAMMING MODE

1. Quick Start – Press the START button for Quick Start / Manual mode. (FIG 9)
2. Program selections are MANUAL → PROGRAM → USER PROGRAM H.R.C. → WATT (FIGURE 9~13)
3. Rotate the Toggle Wheel to select the program you want and press ENTER to confirm.

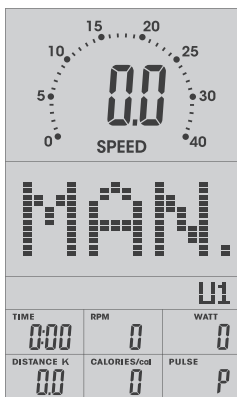

FIGURE 9

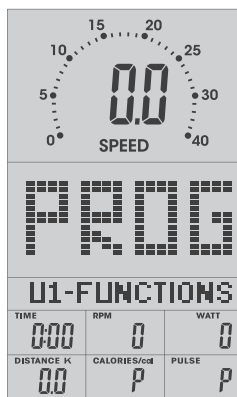

FIGURE 10

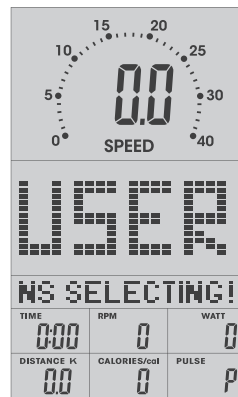

FIGURE 11

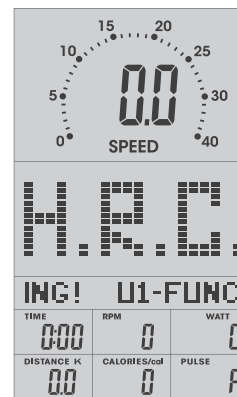

FIGURE 12

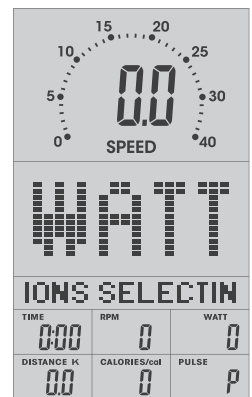

FIGURE 13

QUICK START IN MANUAL

1. Press ENTER to enter into a MANUAL program (FIGURE 14).
2. Press START/STOP to begin program. The resistance level (load) is adjustable during workout.
3. User can press START/ STOP to end program.

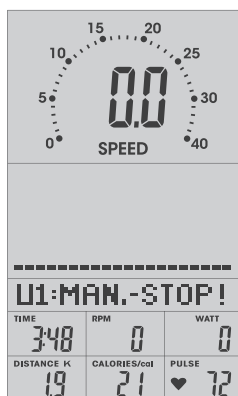

FIGURE 14

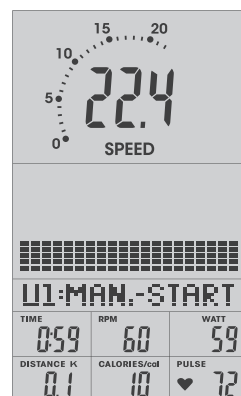

FIGURE 15

MANUAL MODE

1. After selecting MANUAL mode (FIGURE 14), user can adjust the Toggle Wheel to increase / decrease resistance level from 1 to 16, Press ENTER to confirm.
2. TIME, DISTANCE, CALORIES, and PULSE may be preset prior to the start of a workout. Rotate the Toggle Wheel to adjust goal data and press ENTER to confirm. Press RESET to return to the MANUAL setting.
3. Resistance level (load) is adjustable during the workout.

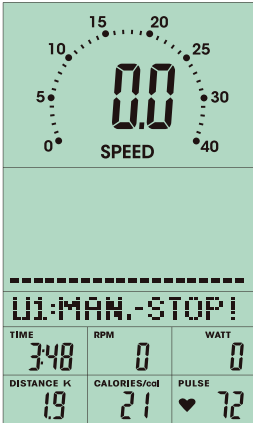

FIGURE 14

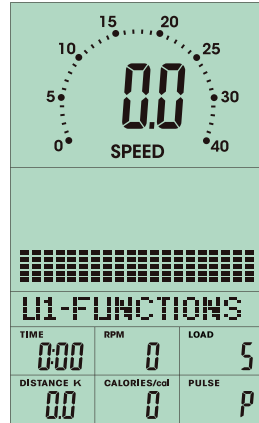

FIGURE 15

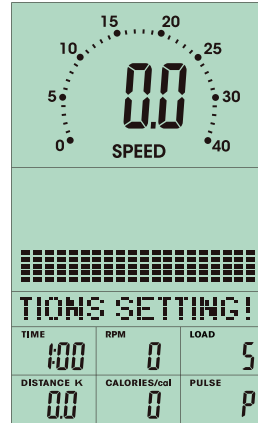

FIGURE 16

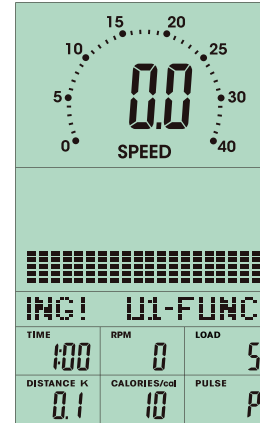

FIGURE 17

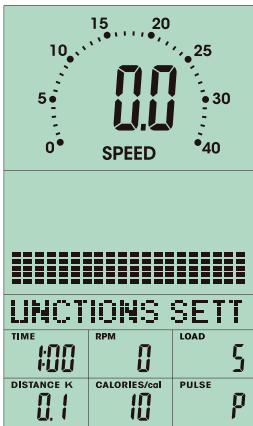

FIGURE 18

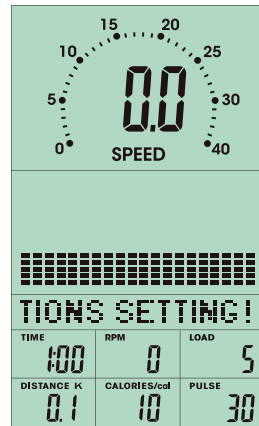

FIGURE 19

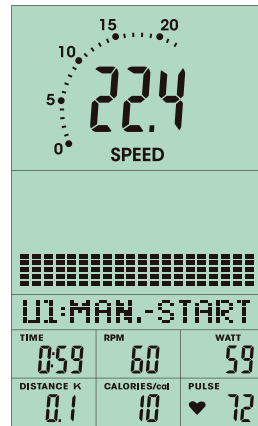
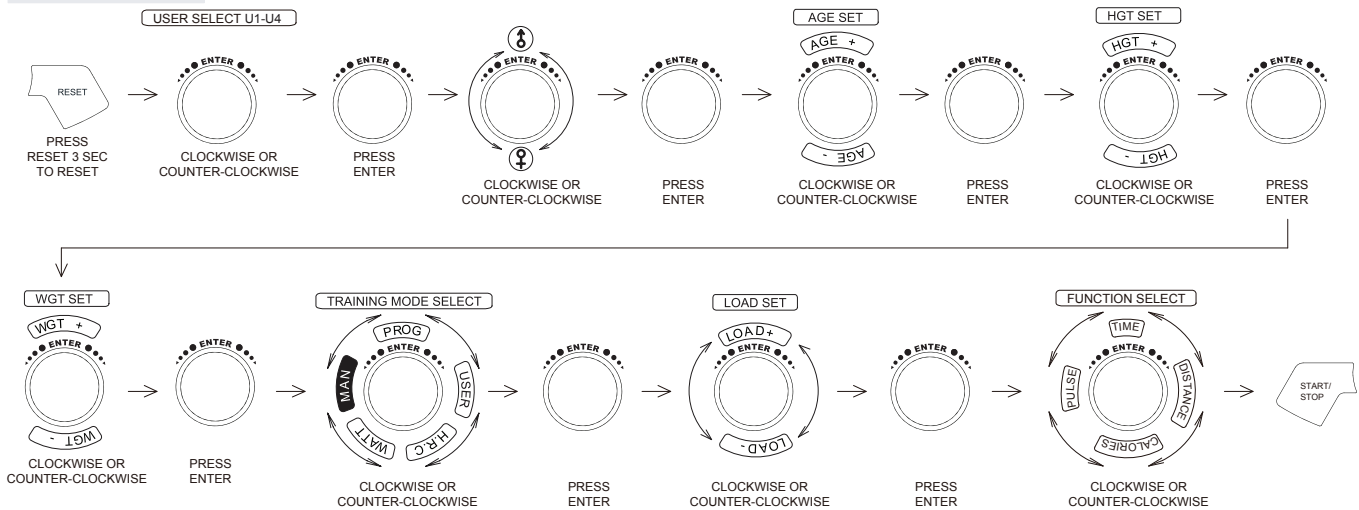

FIGURE 20



FIGURE 21

MANUAL mode



PROGRAM MODE

- After entering PROGRAM mode, turn the Toggle Wheel to select a program from P1 to P12, press ENTER to confirm.
- Preset the desired workout TIME and press START/STOP to start workout or press ENTER to adjust additional target goals such as TIME, DISTANCE, CALORIES, and PULSE.



FIGURE 22

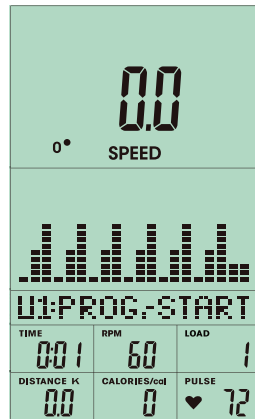

FIGURE 23



FIGURE 24

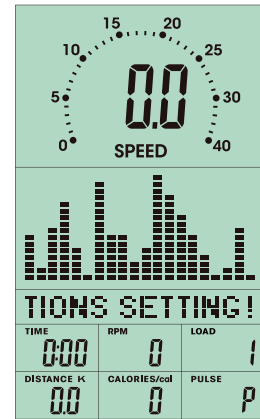
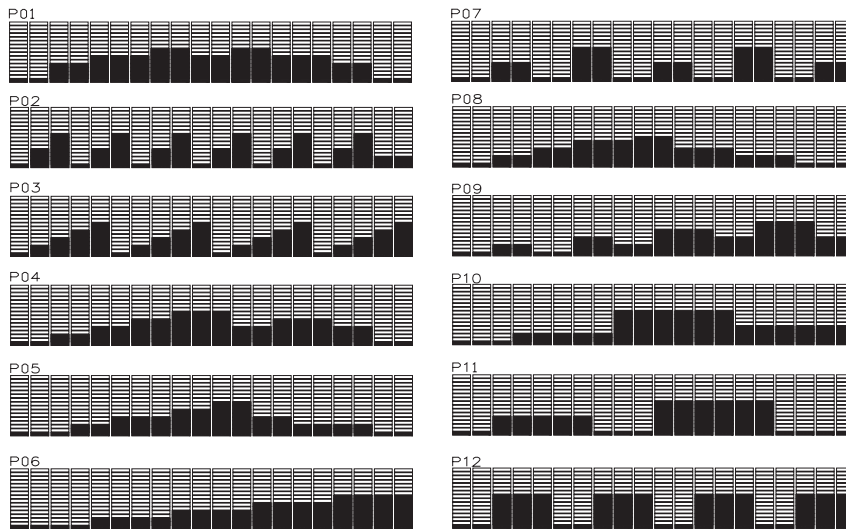
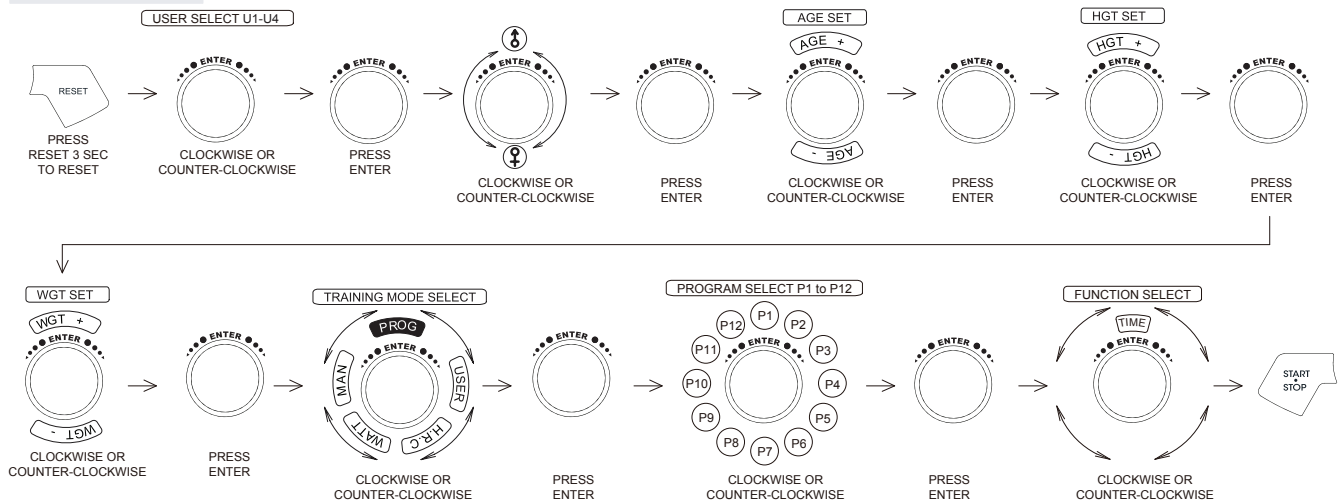

FIGURE 25



PROGRAM mode



USER PROGRAM

1. After entering into the USER PROGRAM mode, the first column of the profile will blink. (FIGURE 26). To customize, turn the Toggle Wheel to adjust the first column resistance level (FIGURE 27), press ENTER and adjust the 2nd column. Repeat 1 – 20 Levels.

While making the profile setting, user can press RESET and return to the menu.

2. When the workout time expires (FIGURE 28~30), the screen will flash and an alarm will sound. The alarm can be stopped by pressing any button.

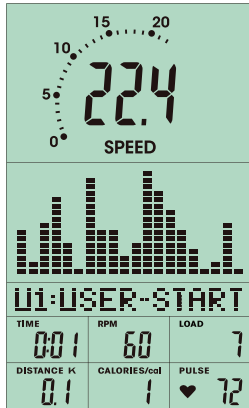

FIGURE 26

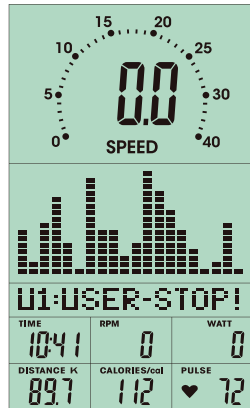

FIGURE 27

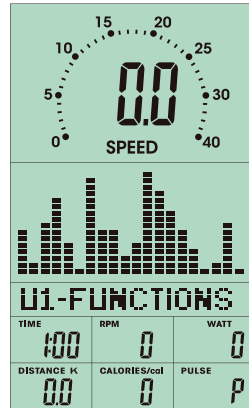

FIGURE 28

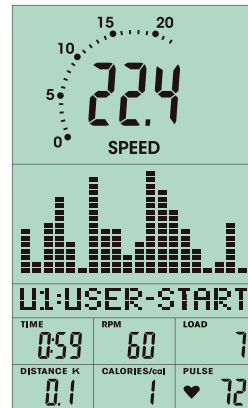

FIGURE 29

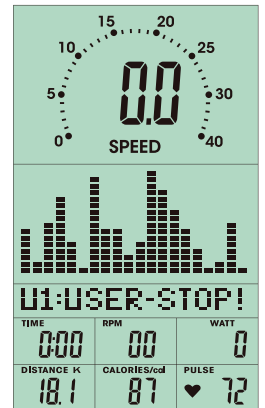
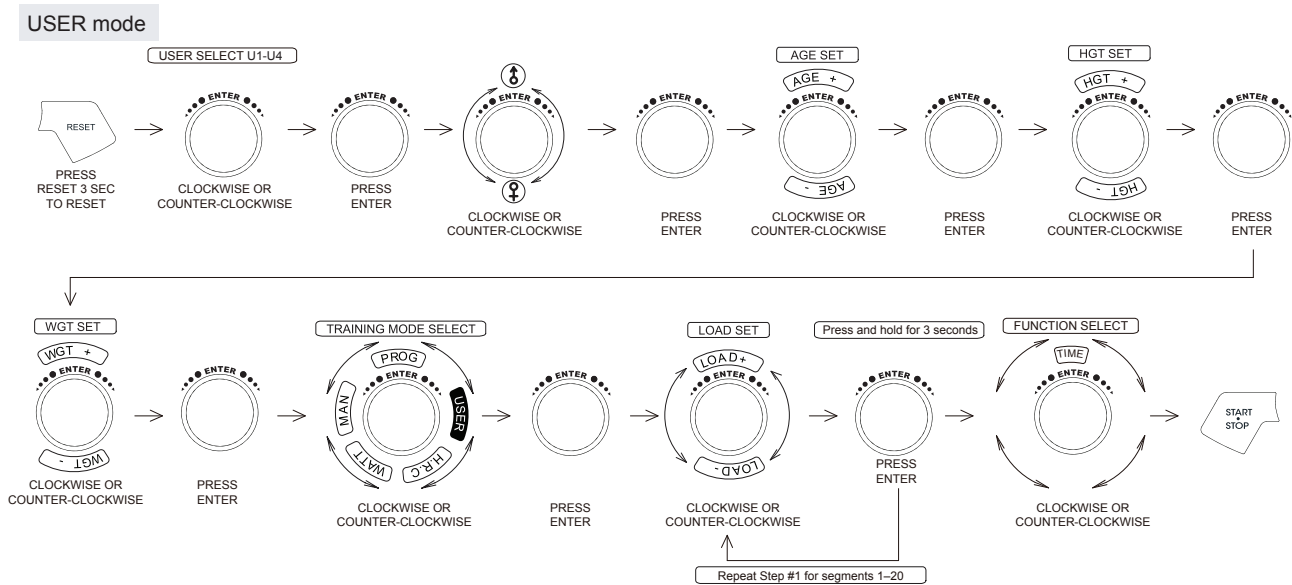

FIGURE 30



HEART RATE CONTROL

1. After entering into HEART RATE CONTROL mode, the screen will show heart rate percentage 55%, 75%, 90% and TARGET. Select desired heart rate percentage by turning the Toggle Wheel. In this mode, the computer will adjust your resistance level (load) to keep you in your desired heart rate range. If your HR is too high, the bike will adjust down your level. If you HR is too low, the bike will adjust the resistance level higher.

2. For your safety, make sure you understand how to choose a desired heart rate goal.

3. Preset desired TIME and then press START/ STOP to begin program.

4. If you have any known heart / cardiovascular issues you must consult with your doctor to find out if you are healthy enough for exercise.

5. Once started, TIME will count down to 0. If there is no HR signal received for 5 seconds, LCD will display until a HR signal is received.

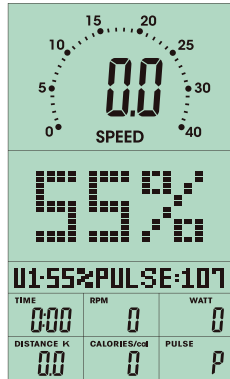

FIGURE 30

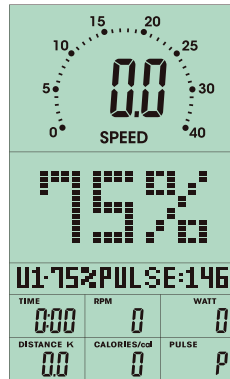

FIGURE 31

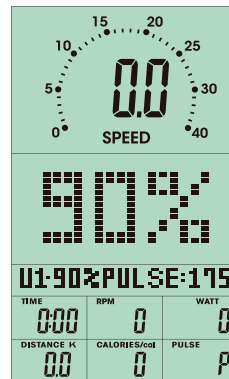

FIGURE 32

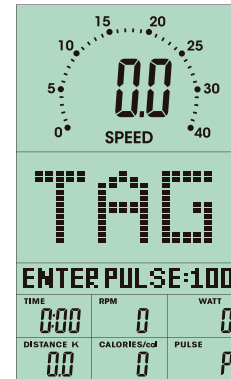

FIGURE 33



FIGURE 34

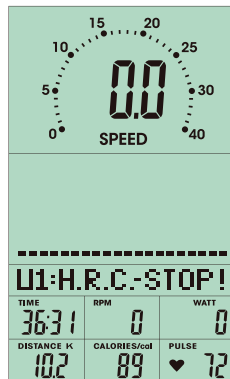

FIGURE 35



FIGURE 36

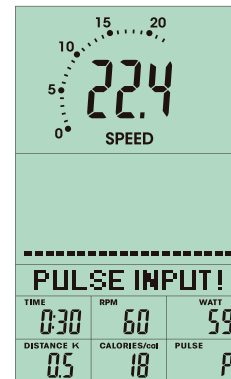
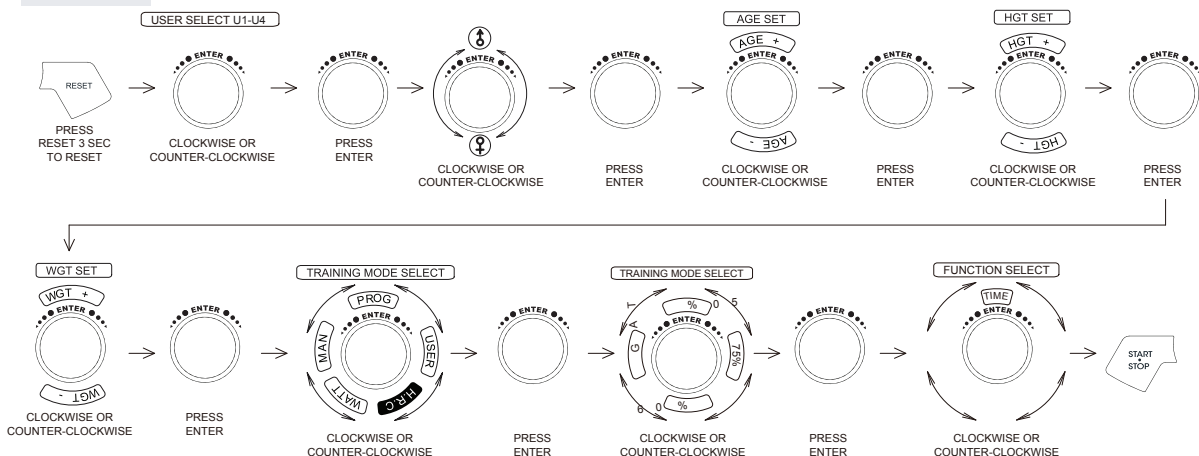

FIGURE 37

H.R.C. mode



CONSTANT WATTS

1. In standby mode, select WATT and press ENTER.
2. WATTS is a unit of measure for how much energy is generated while pedaling the bike.
3. The default WATT value flashing on the screen will read 120. Turn the Toggle Wheel to set a target WATT goal from 10 to 350. Press START button to begin program.
4. Preset the desired TIME then press START/STOP to start program.
5. Once the program starts, TIME will count down to 0 and the program will end, the screen will flash and the alarm will sound. User can press any button to stop the alarm.
6. The target WATT goal is adjustable during a workout. Turn the Toggle Wheel to adjust the desired Watt goal per the instructions below:

• If you have any known heart / cardiovascular issues you must consult with your doctor to find out if you are healthy enough for exercise.



FIGURE 38



FIGURE 39



FIGURE 40

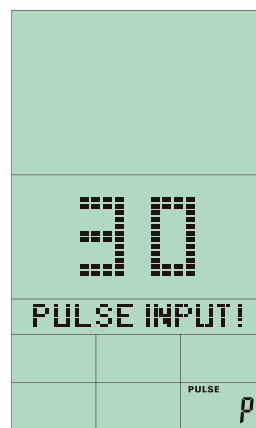
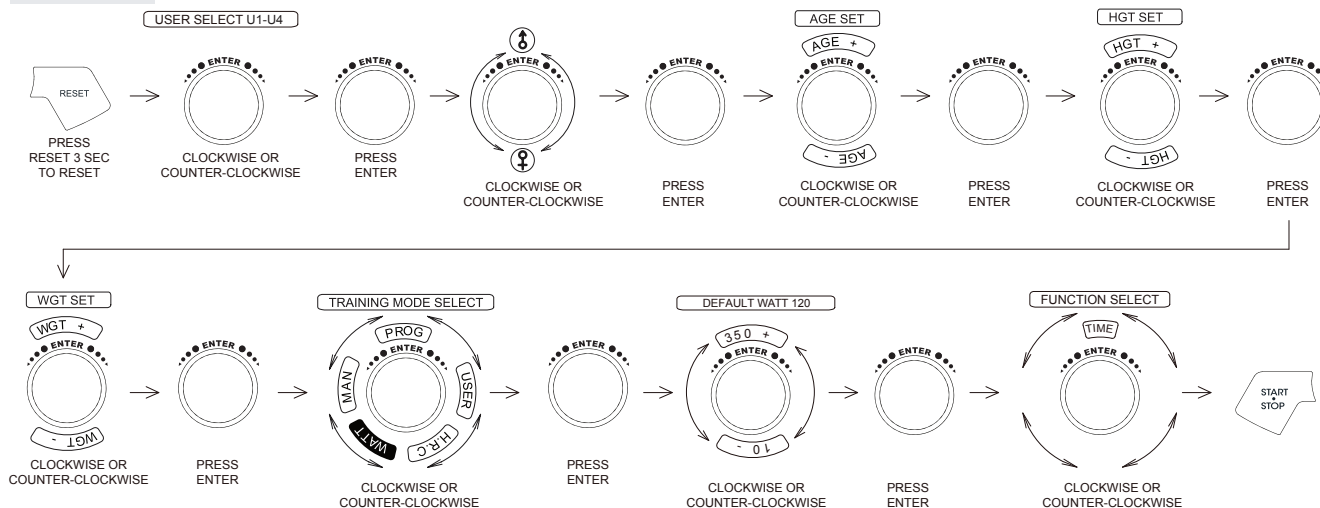

FIGURE 41

WATT mode



RECOVERY

At any point during the workout, while holding onto the side heart rate handgrips, press the “RECOVERY” button. All functions on the display will stop except “TIME” which will start counting down from 00:60 to 00:00. The screen will display your heart rate recovery status with a F1, F2...to F6. F1 is the best, F6 is the worst. (Press the RECOVERY button again to return the main display.) **If you have any known heart / cardiovascular issues you must consult with your doctor to find out if you are healthy enough for exercise.**

Unit of Measure Adjustment – Miles / Kilometers



1. While powering on display, press and hold the START - STOP/RESET buttons simultaneously for 3 seconds.

2. Rotate dial to display Kilometers or Miles.

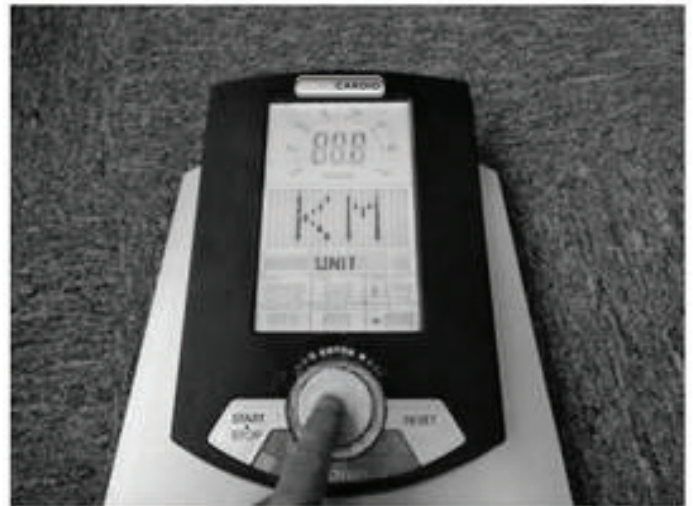

3. Choose preferred unit of measure setting.

4. Press Enter button to confirm settings. The console will automatically power off and new settings are saved.

IMPORTANT MESSAGE ABOUT Bluetooth® – PLEASE READ!

FreeSync™ FTMS Bluetooth® Connections To 3G Cardio Products



We have created videos to help you get started. You can check these videos out here:

www.3gcardio.com/freesync

What you need to know about Bluetooth®:

NOTICE: This console is equipped with an FTMS Bluetooth® interface. Please take note that your mobile device or tablet needs to be compatible with the Bluetooth® interface (Bluetooth® 4.0 or above). To use training apps, you will have to activate (turn on) the Bluetooth® function on your mobile device (tablet or smart phone) and start the fitness app.

Important! Once you turn on the Bluetooth® feature on your device, open the fitness app of your choice and follow the instructions. The app should explain to you the order of events for connecting to the bike. Please follow the instructions given in the app.

You will find the specific Bluetooth® name of your bike on a small sticker on the back of the console.

You can search for fitness apps in the Google Play Store or Apple iOS App Store.

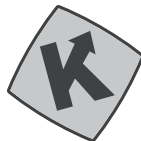
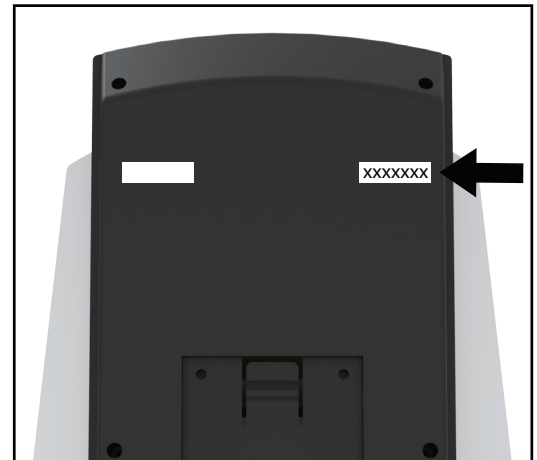

Kinomap™, Zwift™ and iCardio™ and Peloton® are examples of some fitness apps you can try out. Please note that these apps are produced by 3rd party designers. 3G Cardio cannot endorse or approve any 3rd party design software or their success, accuracy, privacy or safety. We also do not track changes in 3rd party software so what may work today with our machines, may not work tomorrow.

Please understand that every device and every app is different. Some apps may work perfectly, some apps may not work at all. Once powered on, your 3G Cardio machine will send out a Bluetooth® signal and your mobile device or tablet will find it. What happens after that depends on your device and the app you choose.

Bluetooth® CONTINUED

You will know that your 3G Cardio bike is pairing successfully if your screen appears the same as the image below.

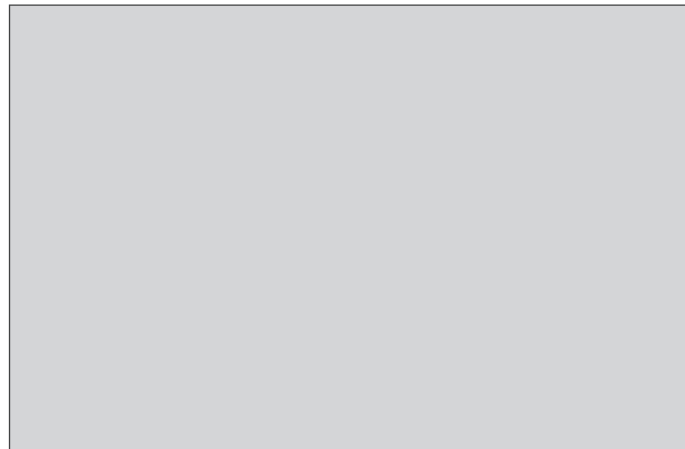

		LOAD

Bluetooth® Software Update for 3G Cardio Elite UB X Upright Bike

A software update is an upgrade which will improve data connections to your Bluetooth® devices and apps.

Determine software version of your bike:

Step 1: Power the 3G Cardio Elite RB X and press the START * STOP button.

Step 2: Hold RESET button for up to 5 seconds.

Step 3: Your software version will be displayed in the center of the screen.
Example "1.2".

Step 4: If your bike display does not read "1.3," then an update is available.

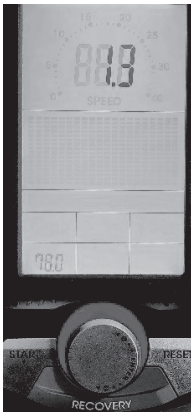

Software update procedure:

Step 5: Download "I CONSOLE" app from the app store (this will only be used for updates. Sorry for any grammatical errors in this app – this is not our design, but it will do what is needed.)



Step 6: Create an account - verify email address – Log back into "I CONSOLE" app.

Step 7: Click on Get Started (below the I Console Logo)

Step 8: Press the tab for QUICK START and select 3G Cardio RB from the drop-down list.

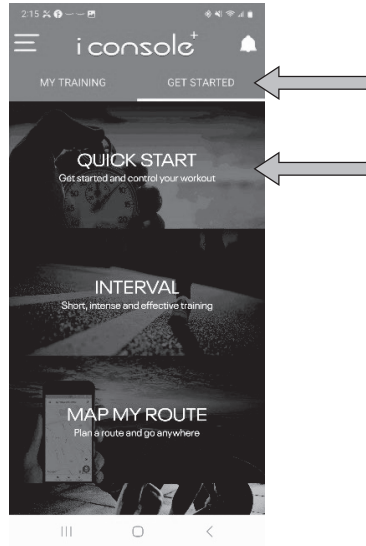

Step 9: Once you pair your bike to the app, go back to the home screen. You may need to close the app and re-open.

Step 10: Select the three bars in the top left corner and choose the Setting tab.

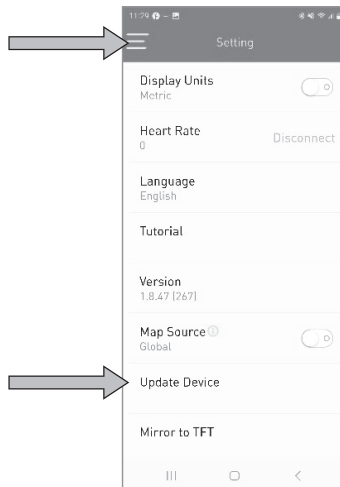

Step 11: At the bottom of the menu, click on Update Device.

Step 12: Select 3G CARDIO from the device list. If an update is available, you will be prompted to download an Update at the bottom of the screen.

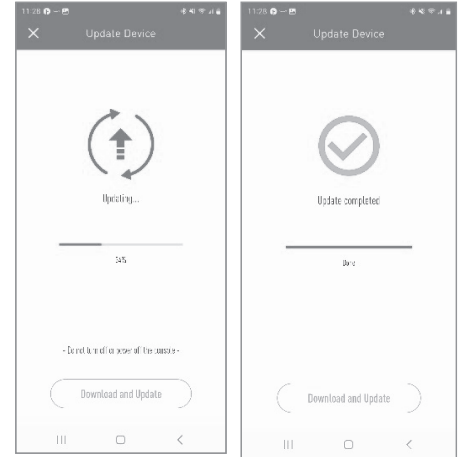

Once the download is updated, your bike will now be upgraded to version 1.3.

Maintenance of your 3G Cardio Bike

WARNING: Always unplug your 3G Cardio Bike prior to cleaning and servicing to avoid electrical hazard or shock.

Always wipe down your exercise bike after a workout. Sweat and perspiration is very corrosive to metal and electronics and a good cleaning after a workout will keep your bike from potential long term damage. Never use unapproved chemicals and solvents to clean your bike.

A protective coating has been applied to the electronics display and only cleaning solutions meant for electronics should be used. This type of cleaner can easily be found online or at your local hardware store and is the same type of cleaner used on flat screen TVs and computers. If you ever have questions about the cleaning and care of your 3G Cardio product, call us at 888-888-7985 or by email at Support@3GCardio.com.

Before each use, it is very important to check the bike for loose bolts, knobs, levers or screws and if found, resolve before performing any exercise. If you hear, feel or notice any type of sound, scraping, clunking or grinding, contact an authorized 3G Cardio service technician or call us directly at 888-888-7985. We will help to resolve the problem.

It will be important to do this asap as a small problem can turn into a bigger problem if left unresolved. It is also important to resolve any issues to prevent a potential safety issue.

After the initial 10-12 hours of use, please check and tighten the crank arm bolts (bolts that attach pedals to crank arms). These bolts must be tightened very securely upon initial assembly and if not tightened securely, very likely may loosen and create an issue with the internal bearings inside the pedals. If not securely tightened and a service issue develops, this may not be covered under the manufacturer's warranty.

WARNING

PLEASE READ! POTENTIAL SERVICE ISSUE!

1. Pedals must be tightened very tight to crank arm.
Failure to do so will result in pedal bearing failure!
2. Use correct size tool to avoid stripping bolts!

**If you have any questions about assembly, service or about the bike in general,
please call us at 888-888-7985.**

Exploded Diagram

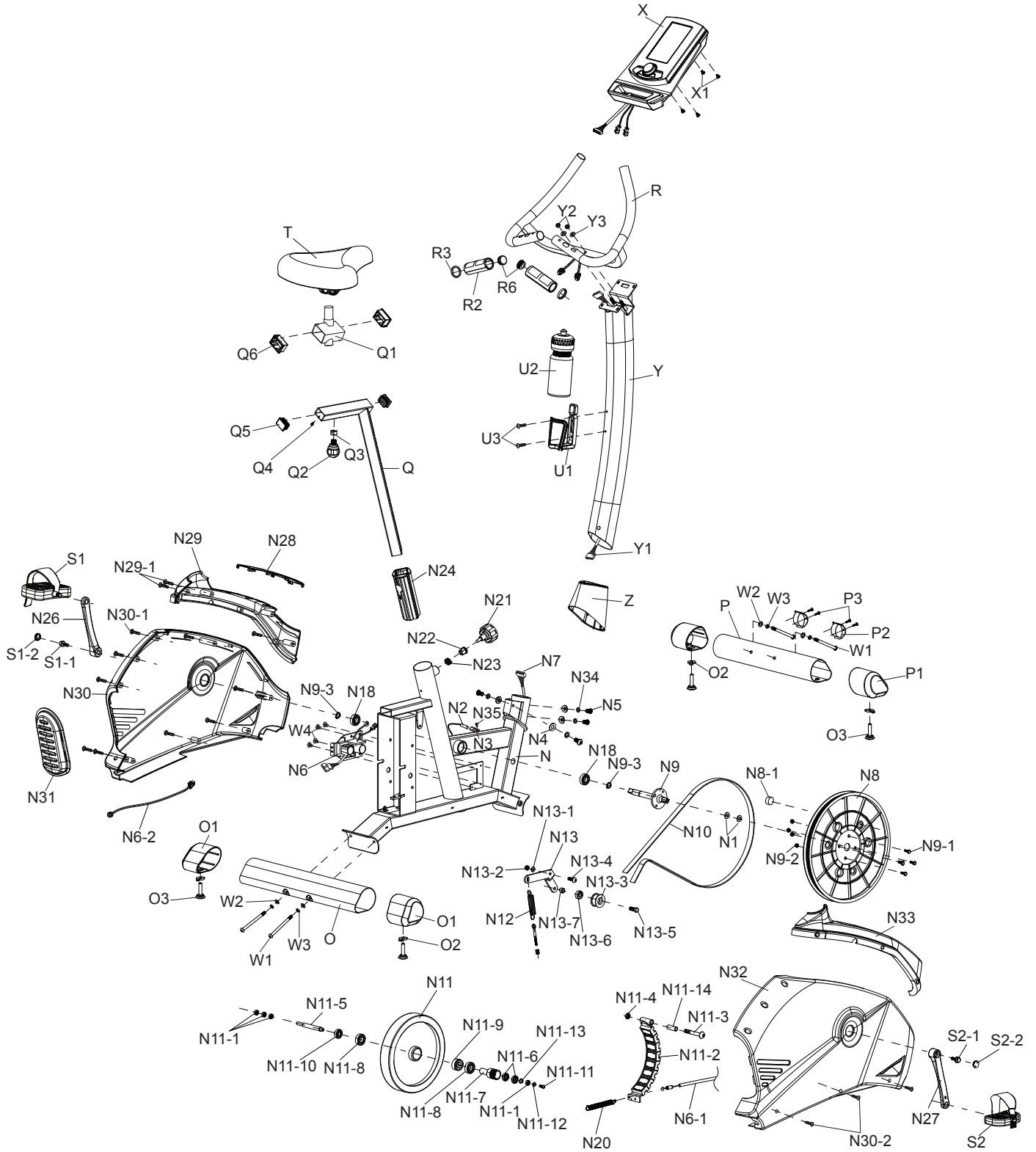

No.	DESCRIPTION	QTY	No.	DESCRIPTION	QTY
N	MAIN FRAME	1	N29-1	Screw $\Phi 3$ x 15L	6
N2	Sensor	1	N30	Shroud Cover (L)	1
N3	Speed Sensor Bracket	1	N30-1	Screw $\Phi 4$ x 20L	10
N4	Washer D16 x D8.5 x 1.5T	4	N30-2	Screw $\Phi 4$ x 20L	6
N5	Screw M8 x 15L	4	N31	Rear Side Cover	1
N6	Motor	1	N32	Shroud Cover (R)	1
N6-1	Tension Cable	1	N33	Upper Side Cover (R)	1
N6-2	DC Line	1	N34	Spring Washer $\Phi 8$	4
N7	Sensor Wire	1	N35	Screw	1
N8	Driving Wheel D240 x J6	1	O	Rear Stabilizer	1
N8-1	Magnet	1	O1	End Cap	2
N9	Axle	1	O2	Adjusting End	4
N9-1	Screw M6 x 15L	4	O3	Adjusting Screw 3/8"	4
N9-2	Nut M6	4	P	Front Stabilizer	1
N9-3	C Type Buckle	2	P1	End Cap	2
N10	Driving Belt	1	P2	Transportation Wheel	2
N11	Magnetic Wheel	1	P3	Screw $\Phi 4$ x 10L	4
N11-1	NUT	4	Q	Seat Support Tube	1
N11-2	Magnetic Housing	1	Q1	Seat Assembly Bracket	1
N11-3	Bolt M6 x 60L	1	Q2	Knob $\phi 38$ x M16 x P1.5 x 15L	1
N11-4	Nut M6	1	Q3	Gap Block	1
N11-5	Axle Center	1	Q4	Screw	1
N11-6	Bearing 6001zz	2	Q5	End Cap	2
N11-7	Pulley	1	Q6	End Cap	2
N11-8	Bearing 6003zz	2	R	Handle Bar	1
N11-9	Bearing	1	R2	Hand Pulse Sensor	2
N11-10	Bearing 6001zz	1	R3	Spaced Ring	2
N11-11	Screw M6 x 12L	1	R6	End Cap	2
N11-12	Washer D19 x D6.2 x 1.5T	1	S1	Pedal (L)	1
N11-13	C Type Buckle	1	S1-1	Screw M8 x 25L	1
N11-14	Case	1	S1-2	Crank Cap	1
N12	SPRING S10	1	S2	Pedal (R)	1
N13	Pressing Plate	1	S2-1	Screw M8 x 25L	1
N13-1	Plastics Washer D23 x D8.2 x 2T	2	S2-2	Crank Cap	1
N13-2	NUT M8	1	T	Seat	1
N13-3	Pressing Wheel	1	U1	Bottle Holder	1
N13-4	Screw M8 x 20L	1	U2	Water Bottle	1
N13-5	Screw M10 x 25L	1	U3	Screw M5X15L	2
N13-6	Bearing 6000zz	1	W1	Screw M5X105L	4
N13-7	Case	1	W2	Washer D16 x D8.5 x 1.5T	4
N18	Bearing	2	W3	Spring Washer $\phi 8$	4
N20	Spring	1	W4	Screw M5 x 10L	4
N21	Knob	1	X	Computer	1
N22	Gap Block M6 x P1.5	1	X1	Screw M5 x 10L	4
N23	Spring	1	Y	Central Supporting Tube	1
N24	Plastic Pipe	1	Y1	Computer Cable	1
N26	Crank (L)	1	Y2	Nut	2
N27	Crank (R)	1	Y3	Washer	2
N28	Upper Cover	1	Z	Plastic Cover	1
N29	Upper Side Cover(L)	1			

3G Cardio Elite UB X Upright Bike Warranty

What does this warranty cover? This warranty covers your 3G Cardio Elite UB X Upright Bike against defects in material and workmanship when used for the purpose intended, under normal conditions, and provided it receives proper care and maintenance.

How long does the coverage last? Warranty starts from the date of purchase and is as follows:

Residential Warranty: Lifetime frame, 7 years parts, 1 year in-home labor.

Model	Labor	Parts	Max User Weight	Daily Usage	Voltage
Elite UB	1 Years	7 Years	350lbs	Up to 4 hours	Input: 100v – 240V – 50/60Hz Output: 9z = 1000mA 9W

*Light Commercial Warranty: 5 years frame, 2 years parts, 1 year on-site labor.

Model	Labor	Parts	Max User Weight	Daily Usage	Voltage Required
Elite UB	1 Year	2 Years	350lbs	Up to 6 hours	Input: 100v – 240V – 50/60Hz Output: 9z = 1000mA 9W

*A 3G Cardio product is placed into a location with a business address and therefore not a residential setting.

What will 3G Cardio do? 3G Cardio's manufacturer warranty will provide a replacement part and/or service at no charge for any part found defective in workmanship or materials during the warranty period.

How do you get service? In order to obtain replacement parts or service as provided by this warranty, please call the location where you purchased the bike or call 3G Cardio (1-888-888-7985) Monday through Friday 9:00 a.m. to 5:00 p.m. Arizona time. Ask to speak to the service department and please have your serial number, date of purchase, original bill of sale and location of purchase available.

This warranty shall not apply to a 3G Cardio Elite UB X Upright Bike which is subject to misuse, neglect, accident, or unauthorized repairs and alterations. This warranty is only valid to the original owner and is nontransferable if sold, traded, bartered or for any other reason of change of ownership. An original bill of sale must be made available stating the purchase date, owner's name, model and place of sale in order to validate warranty. No exceptions will be made otherwise. All other obligations or liabilities, including liability for consequential damages, are hereby excluded. All of the parts for the 3G Cardio Elite UB X Upright can be ordered from 3G Cardio, 14647 So. 50th Street #110, Phoenix, Arizona 85044. Parts will be shipped and billed at the current prices, which are subject to change without notice.

Labor is covered under the manufacturer's warranty period where there is a local 3G Cardio service provider available. For inquiries on service providers and their locations please call toll free 1-888-888-7985.

Register your product at www.3gcardio.com/register



3G Cardio Fitness Equipment
14647 So. 50th Street Suite 110
Phoenix, AZ 85044

1-888-888-7985
www.3GCardio.com